

TAYLORMADE CAPACITOR DISCHARGE STUDWELDING SYSTEM

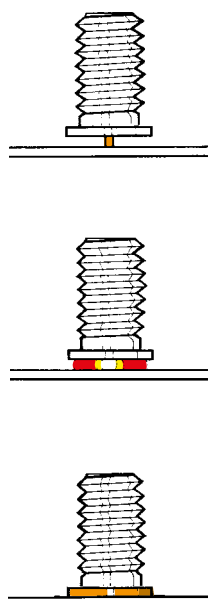

Taylor Studwelding Systems Limited is a specialist in the design, manufacture and supply of Studwelding equipment and studs. Within our range of British built equipment, we will have the system to suit your requirements.

MICRO CONTACT HANDTOOL

Ergonomically designed to provide a fast, safe method of welding in narrow or complicated areas. The Taylor Studwelding Systems Micro Contact Handtool is connected to our standard C2 Contact Handtool using a standard M6 chuck.

Designed and built to exacting standards and meets all required standards, the Micro Contact Handtool is CE and UKCA marked.

TEL: +44 (0)1924 452123 | FAX: +44 (0)1924 430059
EMAIL: sales@taylor-studwelding.com | www.taylor-studwelding.com



A TAYLORMADE SOLUTION FOR CAPACITOR DISCHARGE APPLICATIONS WHERE ACCESS IS AN ISSUE

TAYLOR STUDWELDING SYSTEMS LIMITED

Commercial Road, Dewsbury, West Yorkshire, WF13 2BD, England

TEL: +44 (0)1924 452123 | FAX: +44 (0)1924 430059 | EMAIL: sales@taylor-studwelding.com

www.taylor-studwelding.com

TAYLORMADE CAPACITOR DISCHARGE STUDWELDING SYSTEM



MINIMUM DISTANCES REQUIRED

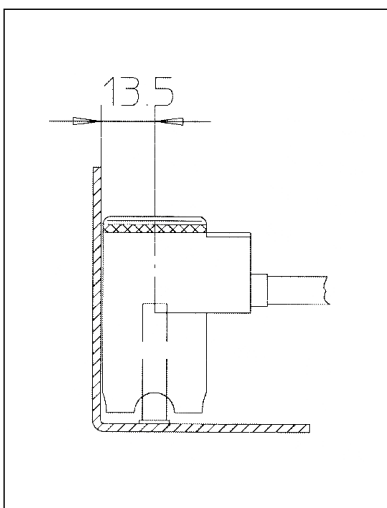

MINIMUM DISTANCE
FROM STUD CENTRE
TO INSIDE FACE OF VERTICAL
WALL IS 13.5mm

SMALLEST OVERHUNG SPACE
INTO WHICH WELDING CAN
OCCUR IS

$$H = 53\text{MM} + L$$

WHERE L = LENGTH OF STUD

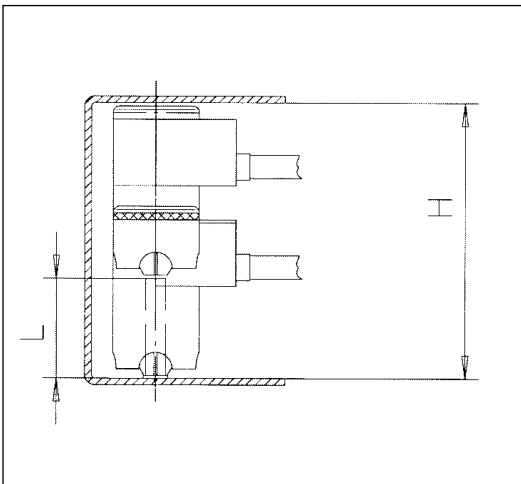

MICRO CONTACT HANDTOOL FEATURES

- Compact.
- Lightweight.
- Easy to fit.
- Easy to use.

Micro Contact Handtool

Welding Range	2-8mm
Stud Length Range	Up to 25mm
Handtool Length	50mm
Handtool Weight	0.30 kg
Part number	71-104-211

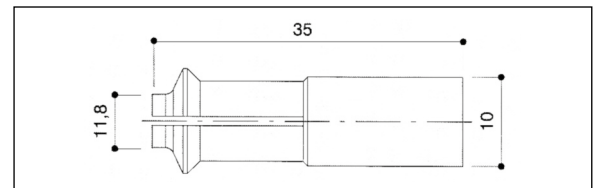

MICRO CONTACT HANDTOOL CHUCKS

Stud Diameter	Part Number
M3	71-104-203
M4	71-104-204
M5	71-104-205
M6	71-104-206
M7.1	71-104-207
M8	71-104-208
M10	71-104-210



TAYLOR STUDWELDING SYSTEMS LIMITED

Commercial Road, Dewsbury, West Yorkshire, WF13 2BD, England

TEL: +44 (0)1924 452123 | FAX: +44 (0)1924 430059 | EMAIL: sales@taylor-studwelding.com

www.taylor-studwelding.com