

# **TAYLOR STUDWELDING SYSTEMS LIMITED**

**CAPACITOR DISCHARGE STUD STOCKLIST**

**GOUJONS SOUDES PAR DECHARGE DE CONDENSATEUR**

**GAMA DE ESPARRAGOS PARA SOLDADURA POR  
DESCARGA DE CONDENSADOR**

**LAGER BESTANDSLISTE FÜR KONDENSATOR  
– ENTLADUNGSSCWEIBOLZEN**



# INTRODUCTION

Taylor Studwelding Systems Limited with over 30 years in the industry has, by blending professional experience with extensive resources, built up an enviable reputation exporting products worldwide, whilst simultaneously developing its position as the UK's leading supplier, designer and manufacturer of studwelding equipment and studs.

At our purpose built computerised office and factory complex our service is fast and efficient and, with over 10,000,000 items constantly in stock, no order is too complex to fulfil.

Taylor Studwelding Systems Limited bénéficie de plus de 30 ans d'expérience dans l'industrie et a acquis une excellente réputation mondiale grâce à la combinaison de sa grande expérience professionnelle et d'importants moyens de production, tout en s'affirmant en tant que leader britannique dans la fourniture, la conception et la fabrication de goujons et d'équipements de soudage de goujons. Notre complexe usine-bureaux entièrement informatisé et spécialement étudié pour une plus grande efficacité nous permet de répondre rapidement à toutes les demandes de nos clients. Avec un stock permanent de plus de 10 millions d'articles, aucune commande n'est trop complexe à exécuter.

Taylor Studwelding Systems Limited, con 30 años de actividades dentro del sector, ha sabido combinar su experiencia profesional con extensos recursos, por lo que ha adquirido una reputación admirable en todo el mundo en la exportación de productos, mientras que en el reino unido lidera el suministro, diseño y fabricación de espárragos y los equipos para soldarlos. Nuestra sede y complejo industrial, construidos especialmente, están informatizados y ofrecen un servicio rápido y eficaz, teniendo existencias disponibles que sobrepasan los 10 millones de piezas, de tal modo que podemos satisfacer cualquier exigencia, por compleja que sea.

Das unternehmen Taylor Studwelding Systems Limited verfügt über eine 30 jährige industrielle erfahrung und hat sich durch die kombination von professionalismus und weitreichenden ressourcen einen bemerkenswerten ruf im weltweiten export von produkten aufgebaut. Die firma ist heute der führende lieferant, designer und produzent von bolzen und geräten für das bolzenaufschweißen. Wir bieten in unseren zweckgebauten und computerisierten büro- und fabrikanlagen einen schnellen und effizienten lieferservice mit mehr als 10.000.000 ständig am lager befindlichen artikeln. Kein auftrag ist zu groß um ihn nicht zu erfüllen.

**"Over 30 years professional experience in the industry."**





750 SQUARE METRES OF PURPOSE BUILT WAREHOUSE HOLDING OVER 10,000,000 ITEMS IN STOCK.

750 METRES CARRES – D'ENTRE POTS CONSTRUITS SPECIALEMENT ET CONTENANT PLUS DE 10.000.000 D'ARTICLES EN STOCK.

DEPOSITO ESPECIALMENTE CONSTRUIDO, CON UN AREA DE 750 METROS CUADRADOS, CUYUS EXISTENCIAS SOBREPASAN 10.000.000 DE PIEZAS.

EIN ZWECKGEBAUTES LAGER MIT CA. 750 QUADRATMETERN UND EINEM LAGERBESTAND VON MEHR ALS 10,000,000 ARTIKELN.

PART OF OUR COMPUTERISED SALES AND STOCK CONTROL FOR FAST AND EFFICIENT SERVICE.

UNE PARTIE DE NOTRE SERVICE DE CONTROLE DES VENTES ET DU STOCK, INFORMATISE POUR LE RENDRE PLUS RAPIDE ET PLUS EFFICACE.

LAS VENTAS Y EXISTENCIAS SE CONTROLAN POR MEDIO DE ORDENADOR, FACILITANDO UN SERVICIO RAPIDO Y EFICAZ.

EIN TEIL UNSERER COMPUTERISIERTEN VERKAUFS - UND LAGERKONTROLLE FUR EINEN SCHNELLEN UND EFFEKTIVEN KUNDENDIENST.



TAYLORMADE DESIGN AND TECHNOLOGY LEADING THE WAY IN RESEARCH AND DEVELOPMENT.

LA CONCEPTION ET LA TECHNOLOGIE TAYLORMADE SONT LA TETE DE LA RECHERCHE ET DU DEVELOPPMENT.

EI DISEÑO Y TECNOLOGIA TAYLORMADE SE ENCUENTRAN A LA VANGUARDIA DE LA INVESTIGACION Y DESARROLLO.

MAßGESCHNEIDERTES DESIGN UND PRAZISIONSTECHNIK SIND FUR FORSCHUNG UND ENTWICKLUNG VON ENTSCHEIDENDER BEDEUTUNG.



QUALITY CONTROL INSPECTION AT ALL LEVELS OF MANUFACTURE.

INSPECTION DE CONTROLE DE LA QUALITE A TOUTES LES ERAPES DE LA FABRICATION.

EL PRODUCTO SE SOMETE A CONTROLES DE CALIDAD EN TODOS LOS NIVELES DE PRODUCCION.

QUALITÄTSKONTROLL-INSPEKTIONEN AUF ALLEN FERTIGUNGSSTUFEN.



WELD STUDS FOR HAND AND AUTOMATIC FEED MUST CONFORM TO BS EN ISO 13918 FOR THREADED, UNTHREADED AND INTERNAL THREADED STUDS RESPECTIVELY SEE TABLES A, B + C. PLEASE SPECIFY IF AUTOFEED OR SMALL FLANGE STUDS FOR ANY OTHER REASON ARE REQUIRED.

LES GOUJONS DESTINES A L'AMENAGE AUTOMATIQUE ET MANUEL DOIVENT SE CONFORMER A LA NORME BS EN ISO 13918 CONCERNENT LES GOUJONS FILETES, LISSES ET TARAUDES, ET CORRESPONDENT AUX TABLEAUX A, B + C. VEUILLEZ SPECIFIER SI VOUS DESIREZ POUR TOUTE AUTRE RAISON DES GOUJONS POUR AMENAGE AUTOMATIQUE OU A COLERETTE REDUITE.

LOS ESPARRAGOS PARA SOLDAR DE ALIMENTACION AUTOMATICA Y MANUAL DEBEN CUMPLIR CON BS EN ISO 13918 PARA ESPARRAGOS ROSCADOS, SIN ROSCA Y DE ROSCA INTERNA RESPECTIVAMENTE. VER TABLAS A, B + C. POR FAVOR INDICAR SI SE REQUIEREN ESPARRAGOS DE ALIMENTACION AUTOMATICA O DE ALA PEQUENA POR CUALQUIER OTRA RAZON.

SCHWEIßBOLZEN FÜR AUTOMATISCHE UND MANUELLE ZUFÜHRUNG MÜSSEN DIE ANFORDERUNGEN BS EN ISO 13918 FÜR BOLZEN MIT UND OHNE GEWINDE, BZW. BOLZEN MIT INNENGEWINDE ERFÜLLEN; SIEHE TABELLEN A, B + C. BITTE ANGEBEN, OB AUTO-ZUFÜHRUNG ODER KLEINE FLANSCHBOLZEN AUS IRGENDWELCHEN ANDEREN GRÜNDEN ERFORDERLICH SIND.

MATERIALS LISTED BELOW GENERALLY CONFORM TO:	LES MATERIAUX FIGURANT SUR LA LISTE CI-DESSOUS SONT CONFORMES A LA SPECIFICATION DES NORMES:	LOS ESPARRAGOS FABRICADOS EN LOS MATERIALES INDICADOS SE CONFORMAN POR LO GENERAL A LAS SIGUIENTES NORMAS:	DIE UNTEN AUFGEFÜHRTEN MATERIALIEN ERFÜLLEN DIE ANFORDERUNGEN DER:	STRENGTHS: Min. load to fracture*					
MS - LOW CARBON MILD STEEL EN 20898 -1	MS - ACIER DOUX A FAIBLE TENEUR DE CARBONE. EN 20898 -1	MS - ACERO DULCE DE BAJO CONTENIDO EN CARBONO EN 20898 -1	MS - BAUSTAHL MIT NIEDRIGEM KOHLENSTOFFGEHALT EN 20898 -1						
SS - STAINLESS STEEL EN ISO 3506 - 3	SS - ACIER INOXYDABLE EN ISO 3506 - 3	SS - ACERO INOXIDABLE EN ISO 3506 - 3	SS - EDELSTAHL EN ISO 3506 - 3						
AA - ALUMINIUM ALLOY EN 573 - 3	AA - ALLIAGE D'ALUMINIUM EN 573 - 3	AA - ALEACION DE ALUMINIO EN 573 - 3	AA - ALUMINIUMLEGIERUNG EN 573 - 3						
PA - PURE ALUMINIUM EN 573 - 3	PA - ALUMINIUM PUR EN 573 - 3	PA - ALUMINIO PURO EN 573 - 3	PA - REINES ALUMINIUM EN 573 - 3						
BR - BRASS (LEAD FREE) ISO 426 - 1 ISO 1638	BR - LAITON (SANS PLOMB) ISO 426 - 1 ISO 1638	BR - LATON (SIN PLOMO) ISO 426 - 1 ISO 1638	BR - MESSING (BLEIFREI) ISO 426 - 1 ISO 1638						
				<p>*except for thin base material</p> <p>1 = MILD STEEL, 2 = STAINLESS STEEL 3 = BRASS, 4 = PURE ALUMINIUM, 5 = Al Mg3</p> <p>1 = ACIER DOUX, 2 = ACIER INOXYDABLE, 3 = LAITON, 4 = ALUMINIUM PUR, 5 = Al Mg3</p> <p>1 = ACERO SUAVE, 2 = ACERO INOXIDABLE, 3 = LATON, 4 = ALUMINIO PURO, 5 = Al Mg3</p> <p>1 = WEICHSTAHL, 2 = EDELSTAHL, 3 = MESSING, 4 = REINES ALUMINIUM, 5 = Al Mg3</p>					

SPECIALS – STUDS SUPPLIED TO CUSTOMER REQUIREMENTS.

PRODUITS SPECIAUX – GOUJONS FOURNIS SUIVANT LES SPECIFICATIONS DU CLIENT.

ESPARRAGOS POR ENCARGO ESPECIAL DEL CLIENTE

SPEZIALITÄTEN – BOLZEN AUF KUNDENWUNSCH



WELDABILITY:	SOUDABILITE:	SOLDABILIDAD:	BOLZENMATERIAL:	STUD MATERIAL				
				MS	SS	AA	PA	BR
STEEL UP TO 0.35 CARBON	ACIER JUSQ'A 0.35 DE CARBONE	ACERO - CARBONO 0,35 MAX.	STAHL BIS ZU 0,35 KOHLENSTOFF	▲	▲	✘	✘	▲
STEEL UP TO 0.60 CARBON	ACIER JUSQ'A 0.60 DE CARBONE	ACERO - CARBONO 0,60 MAX.	STAHL BIS ZU 0,60 KOHLENSTOFF	▲	●	✘	✘	▲
AUSTENITIC STAINLESS STEEL	ACIER INOXYDABLE - AUSTENITIQUE	ACERO INOXIDABLE AUSTENITICO	AUSTENIT-EDELSTAHL	▲	▲	✘	✘	●
ZINTEC COATED STEEL	ACIER A REVETEMENT ZINTEC	ACERO RECUBIERTO DE ZINTEC	ZINTEC-BESCHICHTETER STAHL	●	●	✘	✘	▲
ELECTRO-GALVANISED STEEL	ACIER ELECTRO-ZINQUE	ACERO GALVANIZADO	ELEKTRO-GALVANISIERTERSTAHL	●	●	✘	✘	●
HOT ROLLED STRUCTURAL STEEL	ACIER STRUCTURAL LAMINE A CHAUD	ACERO ESTRUCTURAL LAMINADO EN CALIENTE	WARMGEWALZTER STRUKTURSTAHL	●	●	✘	✘	✘
ALUMINIUM ALLOY	ALLIAGE D'ALUMINIUM	ALEACION DE ALUMINIO	ALUMINIUMLEGIERUNG	✘	✘	▲	●	✘
PURE ALUMINIUM - PA	ALUMINIUM PUR - PA	ALUMINIO PURO	REINES ALUMINIUM - PA	✘	✘	●	▲	✘
LEAD FREE BRASS	LAITON SANS PLOMB	LATON SIN PLOMO	BLEIFREIES MESSING	●	▲	✘	✘	▲
LEAD FREE COPPER	CUIVRE SANS PLOMB	COBRE SIN PLOMO	BLEIFREIES KUPFER	●	●	✘	✘	▲

WELD CONDITION: ▲ GOOD - BONNE - BUENA - GUT ● FAIR - PASSABLE - REGULAR - BEFRIEDIGEND ✘ NOT WELDABLE - NON SOUDABLE - INSOLDABLE - NICHT SCHWEIßBAR

## A

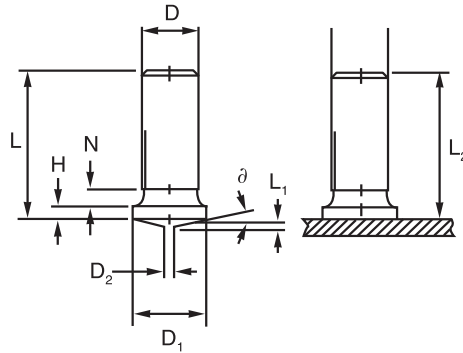
**THREADED STUDS**  
EN ISO 13918**GOUJONS FILETES**  
EN ISO 13918**ESPARRAGOS ROSCADOS**  
EN ISO 13918**BOLZEN MIT GEWINDE**  
EN ISO 13918

D	L +0.6 1) 0	D <sub>1</sub> ±0.2	D <sub>2</sub> ±0.08	L <sub>1</sub> ±0.05	H	N MAX	∅
M3	6, 8 10, 12 16, 20	4,5	0,60	0,55	0.7 to 1.4	1,5	3°
M4	8, 10 12, 16 20, 25	5,5	0,65				
M5	10,12,16	6,5	0,75	0,80	0.8 to 1.4	2	
M6	20,25,30	7,5					
M8	12, 16 20, 25 30	9		0,85	0.8 to 1.4	3	

1) Other lengths are subject to agreement.

## B

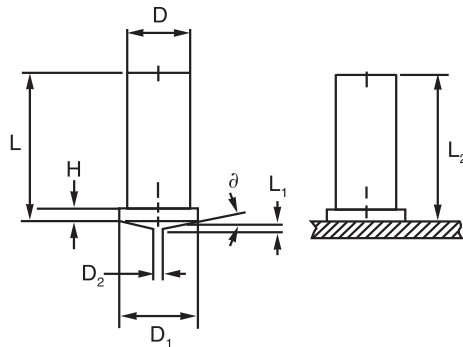
**NO-THREAD STUDS**  
EN ISO 13918**GOUJONS LISSES**  
EN ISO 13918**ESPARRAGOS SIN ROSCA**  
EN ISO 13918**BOLZEN OHNE GEWINDE**  
EN ISO 13918

D	L +0.6	D <sub>1</sub> ±0.2	D <sub>2</sub> ±0.08	L <sub>1</sub> ±0.05	H	L <sub>2</sub>	∅
∅3	See Table	4.5	0.65	0.55	0.7 to 1.4	L - 0,3	3°
∅4		5.5					
∅5		6.5	0.75	0.8	0.8 to 1.4		
∅6		7.5					

## C

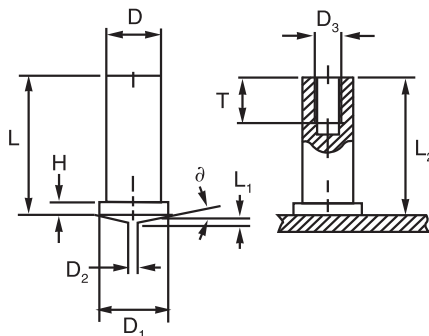
**INTERNAL THREADED STUDS**  
EN ISO 13918**DOUILLES TARAUEES**  
EN ISO 13918**ESPARRAGOS ROSCA INTERNA**  
EN ISO 13918**BOLZEN MIT INNENGEWINDE**  
EN ISO 13918

D	L +0.6	D <sub>1</sub> ±0.2	D <sub>2</sub> ±0.08	L <sub>1</sub> ±0.05	H	D <sub>3</sub>	T	L <sub>2</sub>	∅
∅5	See Table	6.5	0.75	0.8	0.8 to 1.4	M3	5	L - 0,3	3°
∅6		7.5				M4	6		

Threaded Studs Goujons Filetes Pernos Roscados Kondensatorentladung Mit Gewinde	PT
Unthreaded Studs Goujons Lisses Pernos Sin Rosca Kondensatorentladung Ohne Gewinde	UT
Internally Threaded Studs Goujons Taraudes Pernos Con Rosca Interior Kondensatorentladung Innengewinde	IT

**TYPES OF CAPACITOR DISCHARGE STUDS AND THEIR REFERENCE CODE****TYPES DES GOUJONS SOUDES PAR DECHARGE DE CONDENSATEUR ET CODES DU REFERENCE****TIPOS DE PERNOS DE SOLDADURA POR DESCARGA DE CONDENSATOR Y SUS CODIGOS DE REFERENCIA****VERSCHIEDENE TYPEN VON SCHWEIßBOLZEN MIT DEREN ARTIKELNUMMER**

# HOW TO ORDER

5

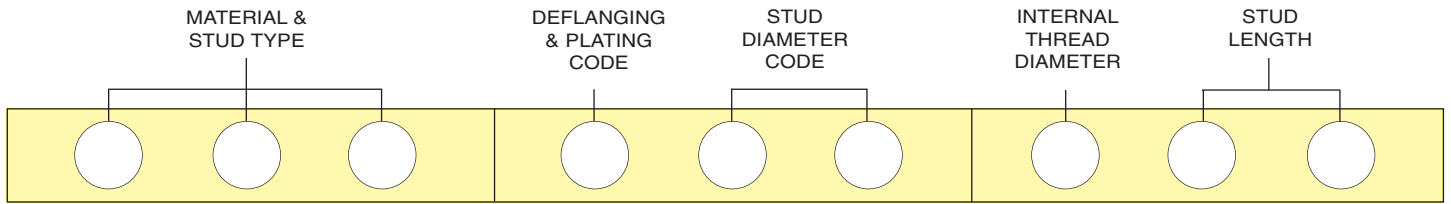

DEFLANGE & PLATING CODE	DIAMETER CODE	INTERNAL THREAD DIAMETER	STUD LENGTH
0 - STANDARD FINISH	03 - 3MM	3 - M3	06 - 6MM
1 - ZINC PLATE	04 - 4MM	4 - M4	08 - 8MM
2 - NICKEL PLATE	05 - 5MM	5 - M5	10 - 10MM
9 - DE-FLANGE	06 - 6MM	6 - M6	12 - 12MM
	08 - 8MM		16 - 16MM
	10 - 10MM		20 - 20MM
			ETC.

0	0	1	CAPACITOR DISCHARGE MILD STEEL THREADED
0	0	2	CAPACITOR DISCHARGE STAINLESS STEEL THREADED
0	0	3	CAPACITOR DISCHARGE AI Mg3 THREADED
0	0	4	CAPACITOR DISCHARGE 99.5% ALUMINIUM THREADED
0	0	5	CAPACITOR DISCHARGE BRASS THREADED
0	1	1	CAPACITOR DISCHARGE MILD STEEL UNTHREADED
0	1	2	CAPACITOR DISCHARGE STAINLESS STEEL UNTHREADED
0	1	3	CAPACITOR DISCHARGE AI Mg3 UNTHREADED
0	1	4	CAPACITOR DISCHARGE 99.5% ALUMINIUM UNTHREADED
0	1	5	CAPACITOR DISCHARGE BRASS UNTHREADED
0	1	6	CAPACITOR DISCHARGE MILD STEEL WELD NAILS
0	1	7	CAPACITOR DISCHARGE STAINLESS STEEL WELD NAILS
0	1	8	CAPACITOR DISCHARGE AI Mg3 WELD NAILS
0	1	9	CAPACITOR DISCHARGE NEEDLE STUDS
0	2	1	CAPACITOR DISCHARGE MILD STEEL INTERNAL THREAD
0	2	2	CAPACITOR DISCHARGE STAINLESS STEEL INTERNAL THREAD
0	2	3	CAPACITOR DISCHARGE AI Mg3 INTERNAL THREAD
0	2	4	CAPACITOR DISCHARGE 99.5% ALUMINIUM INTERNAL THREAD
0	2	5	CAPACITOR DISCHARGE BRASS INTERNAL THREAD

# SAMPLE ORDER

- 1) TO ORDER: M5 X 10 MILD STEEL THREADED CAPACITOR DISCHARGE STUDS  
USE THE FOLLOWING CODE: 001-005-010

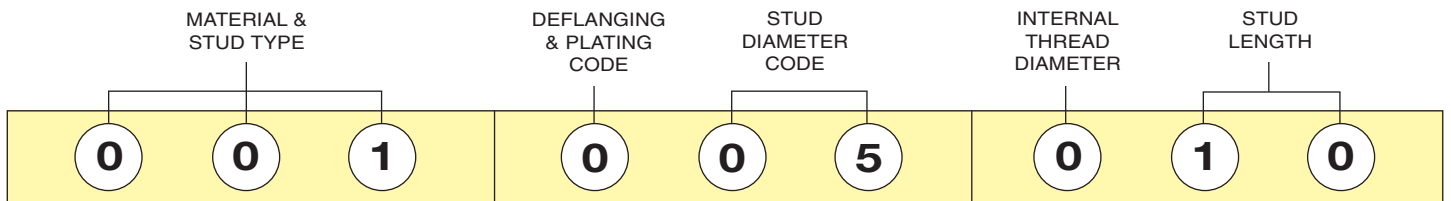

- 2) TO ORDER: 6mm X 30 STAINLESS STEEL UNTHREADED CAPACITOR DISCHARGE STUDS  
USE THE FOLLOWING CODE: 012-006-030

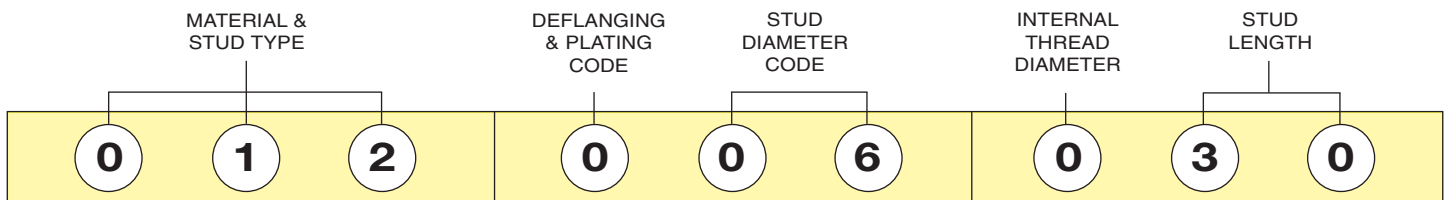

- 3) TO ORDER: M4 X 6 X 20 ALUMINIUM ALLOY (AI Mg3) INTERNALLY THREADED CAPACITOR DISCHARGE STUDS  
USE THE FOLLOWING CODE: 023-006-420

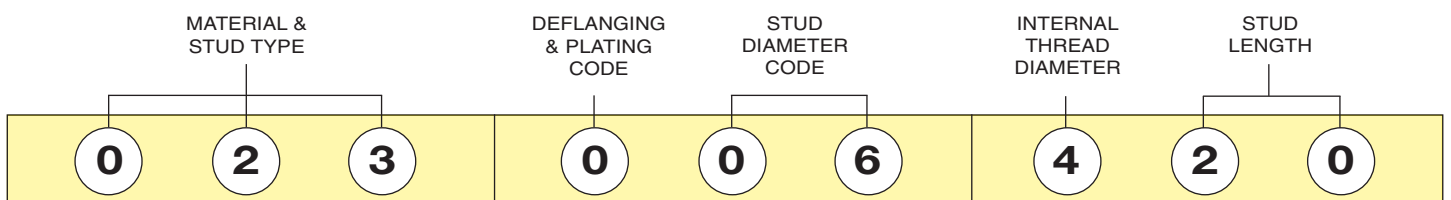

# INSTRUCTIONS POUR LES COMMANDES

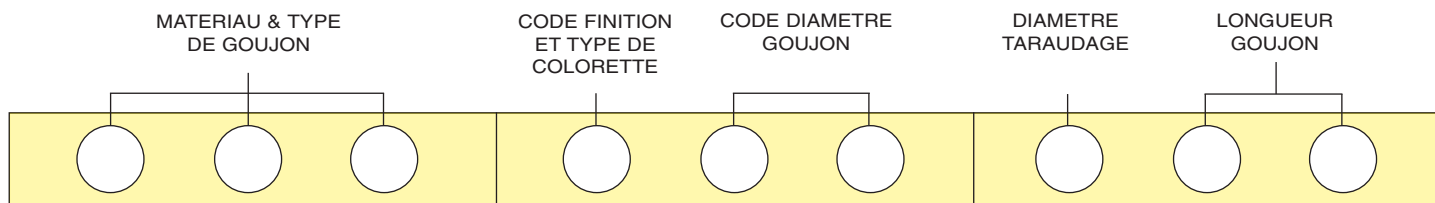

CODE FINITION ET TYPE DE COLORETTE	CODE DIAMETRE GOUJON	DIAMETRE TARAUDAGE	LONGUEUR GOUJON
0 - FINITION STANDARD	03 - 3MM	3 - M3	06 - 6MM
1 - ZINGUE	04 - 4MM	4 - M4	08 - 8MM
2 - NICKEL	05 - 5MM	5 - M5	10 - 10MM
	06 - 6MM	6 - M6	12 - 12MM
	08 - 8MM		16 - 16MM
	10 - 10MM		20 - 20MM
			ETC.

0	0	1	_____	GOUJONS SOUDES C.D. - ACIER DOUX FILETE
0	0	2	_____	GOUJONS SOUDES C.D. - ACIER INOXYDABLE FILET
0	0	3	_____	GOUJONS SOUDES C.D. - Al Mg3 FILETE
0	0	4	_____	GOUJONS SOUDES C.D. - ALUMINIUM 99,5% FILETE
0	0	5	_____	GOUJONS SOUDES C.D. - LAITON FILETE
0	1	1	_____	GOUJONS SOUDES C.D. - ACIER DOUX LISSE
0	1	2	_____	GOUJONS SOUDES C.D. - ACIER INOXYDABLE LISSE
0	1	3	_____	GOUJONS SOUDES C.D. - Al Mg3 LISSE
0	1	4	_____	GOUJONS SOUDES C.D. - ALUMINIUM 99,5% LISSE
0	1	5	_____	GOUJONS SOUDES C.D. - LAITON LISSE
0	1	6	_____	GOUJONS SOUDES C.D. - CLOUS ACIER DOUX
0	1	7	_____	GOUJONS SOUDES C.D. - CLOUS INOX.
0	1	8	_____	GOUJONS SOUDES C.D. - CLOUS Al Mg3
0	1	9	_____	GOUJONS SOUDES C.D. - AIGUILLES
0	2	1	_____	GOUJONS SOUDES C.D. - DOUILLES TARAUDEES EN ACIER DOUX
0	2	2	_____	GOUJONS SOUDES C.D. - DOUILLES TARAUDEES EN INOX.
0	2	3	_____	GOUJONS SOUDES C.D. - DOUILLES TARAUDEES EN Al Mg3
0	2	4	_____	GOUJONS SOUDES C.D. - DOUILLES TARAUDEES EN ALUM. 99,5%
0	2	5	_____	GOUJONS SOUDES C.D. - DOUILLES TARAUDEES EN LAITON

## COMMANDE D'ECHANTILLON

1) POUR COMMANDER DES GOUJONS A SOUDER C.D. EN ACIER DOUX FILETE M5 X 10  
RAPPELER LE CODE SUIVANT: **001-005-010**

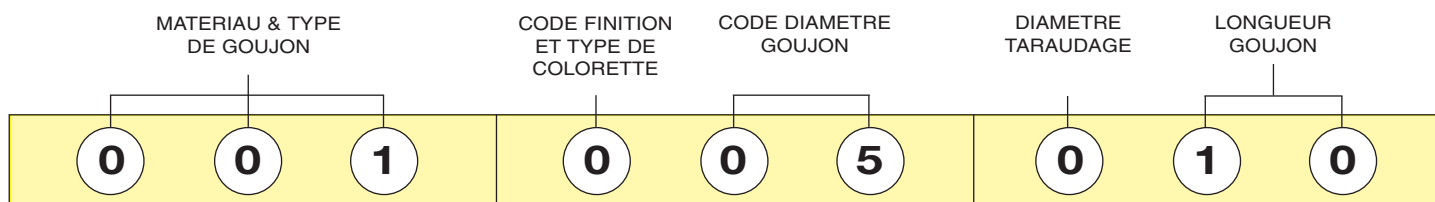

2) POUR COMMANDER DES GOUJONS A SOUDER C.D. EN ACIER INOXYDABLE LISSES 6MM X 30  
RAPPELER LE CODE SUIVANT: **012-006-030**

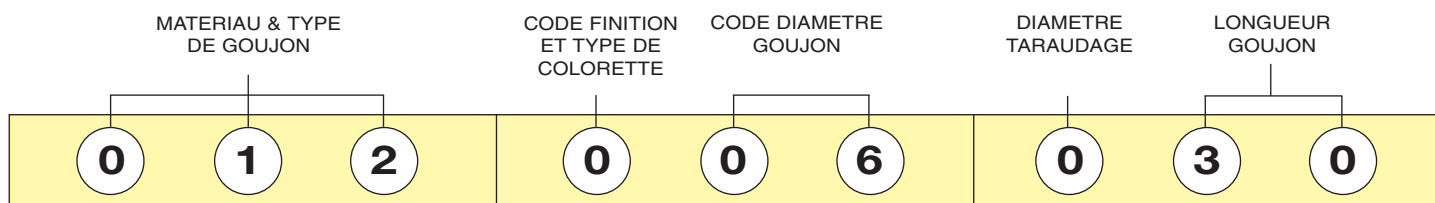

3) POUR COMMANDER DES DOUILLES A SOUDER C.D. EN ALLIAGE D'ALUMINIUM (Al Mg3) AVEC TARAUDAGE M4 X 6 X 20  
RAPPELER LE CODE SUIVANT: **023-006-420**

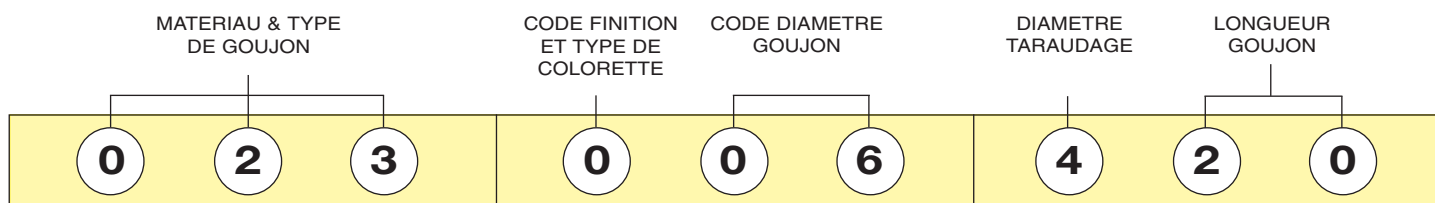

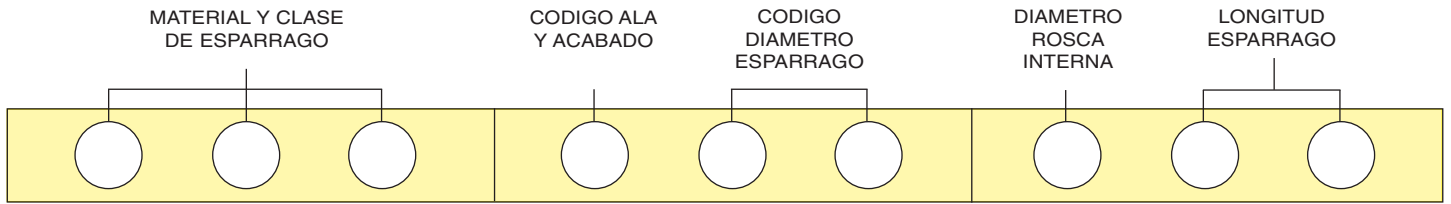

CODIGO ALA Y ACABADO	CODIGO DIAMETRO	DIAMETRO ROSCA INTERNA	LONGITUD ESPARRAGO
0 - ACABADO NORMAL	03 - 3MM	3 - M3	06 - 6MM
1 - ZINCADO	04 - 4MM	4 - M4	08 - 8MM
2 - NIQUELADO	05 - 5MM	5 - M5	10 - 10MM
9 - SIN ALA	06 - 6MM	6 - M6	12 - 12MM
	08 - 8MM		16 - 16MM
	10 - 10MM		20 - 20MM
			ETC.

0	0	1	ACERO DULCE ROSCADO – DESCARGA DE CONDENSADOR
0	0	2	ACERO INOXIDABLE DE ROSCAR – DESCARGA DE CONDENSADOR
0	0	3	AI Mg3 DE ROSCAR – DESCARGA DE CONDENSADOR
0	0	4	ALUMINIO 99,5% DE ROSCAR – DESCARGA DE CONDENSADOR
0	0	5	LATON DE ROSCAR – DESCARGA DE CONDENSADOR
0	1	1	ACERO DULCE SIN ROSCA – DESCARGA DE CONDENSADOR
0	1	2	ACERO INOXIDABLE SIN ROSCA – DESCARGA DE CONDENSADOR
0	1	3	AI Mg3 SIN ROSCA – DESCARGA DE CONDENSADOR ALUMINIO 99,5 SIN ROSCA
0	1	4	DESCARGA DE CONDENSADOR
0	1	5	LATON SIN ROSCA – DESCARGA DE CONDENSADOR
0	1	6	PUNTA DE AISLAMIENTO DE ACERO DULCE – DESCARGA DE CONDENSADOR
0	1	7	PUNTA DE AISLAMIENTO DE ACERO INOXIDABLE – DESCARGA CONDENSADOR
0	1	8	PUNTA DE AISLAMIENTO DE AI Mg3 – DESCARGA DE CONDENSADOR
0	1	9	ESPARRAGOS AGUJA – DESCARGA DE CONDENSADOR
0	2	1	ACERO DULCE ROSCA INTERNA – DESCARGA DE CONDENSADOR
0	2	2	ACERO INOXIDABLE ROSCA INTERNA – DESCARGA DE CONDENSADOR
0	2	3	AI Mg3 ROSCA INTERNA – DESCARGA DE CONDENSADOR
0	2	4	ALUMINIO 99,5% ROSCA INTERNA – DESCARGA DE CONDENSADOR
0	2	5	LATON ROSCA INTERNA – DESCARGA DE CONDENSADOR

## EJEMPLO PEDIDO

- 1) PARA ENCARGAR: M5 X 10 ESPARRAGOS DE ACERO DULCE ROSCADOS, DESCARGA DE CONDENSADOR, EMPLEAR EL SIGUIENTE CODIGO: **001-005-010**

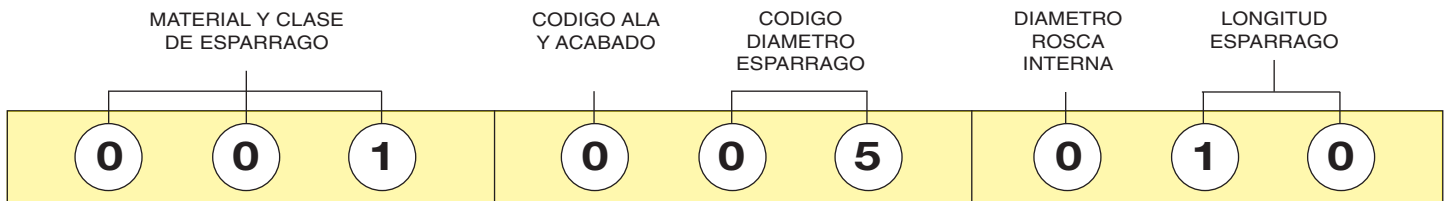

- 2) PARA ENCARGAR: 6MM X 30 ESPARRAGOS DE ACERO INOXIDABLE SIN ROSCA, DESCARGA CONDENSADOR, EMPLEAR EL SIGUIENTE CODIGO: **012-006-030**

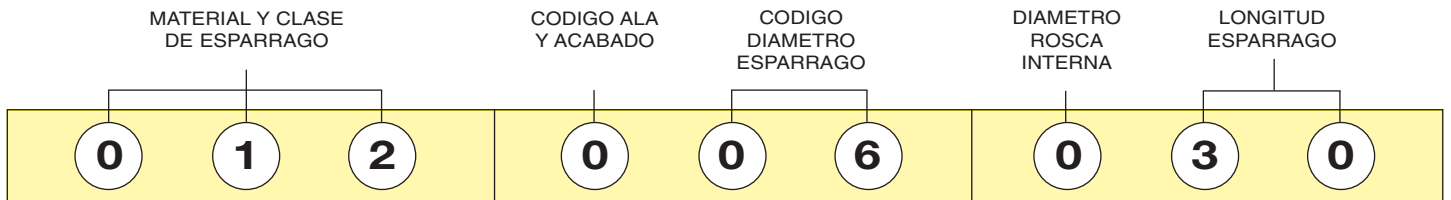

- 3) PARA ENCARGAR: M4 X 20 ESPARRAGOS DE ALEACION DE ALUMINIO, (AI Mg3) CON ROSCA INTERNA, DESCARGA CONDENSADOR, EMPLEAR EL SIGUIENTE CODIGO: **023-006-420**

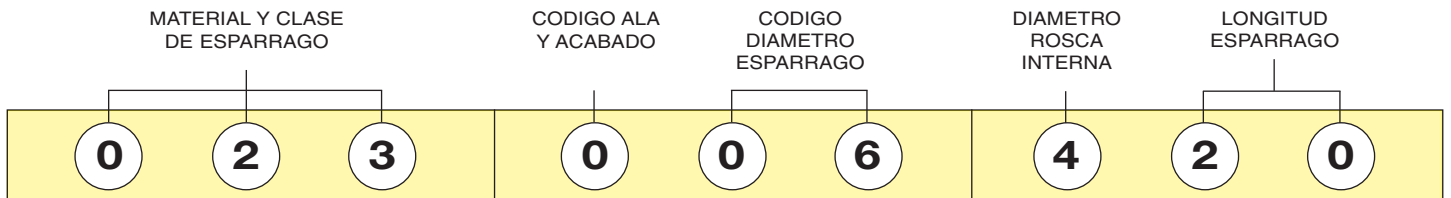



## BESTELLUNG

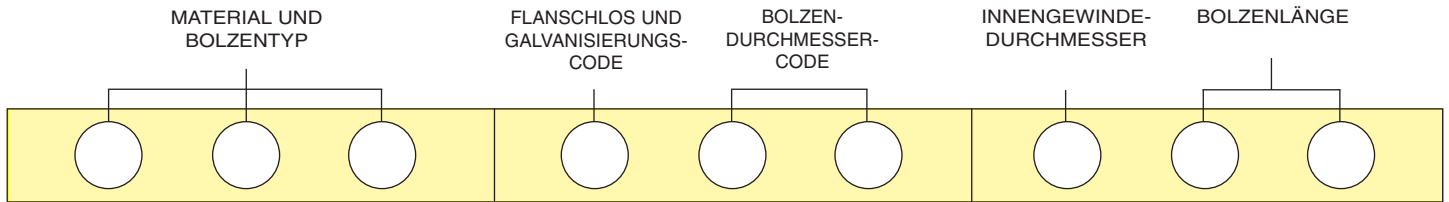

**FLANSCHLOS UND GALVANISIERUNGSCODE**  
 0 - STANDARDBESCHICHTUNG  
 1 - ZINKBESICHTUNG  
 2 - NICKELBESICHTUNG  
 9 - ENTFLANSCHT

**BOLZEN-DURCHMESSERCODE**  
 03 - 3MM  
 04 - 4MM  
 05 - 5MM  
 06 - 6MM  
 08 - 8MM  
 10 - 10MM

**INNENGEWINDE-DURCHMESSER**  
 3 - M3  
 4 - M4  
 5 - M5  
 6 - M6

**BOLZENLÄNGE**  
 06 - 6MM  
 08 - 8MM  
 10 - 10MM  
 12 - 12MM  
 16 - 16MM  
 20 - 20MM  
 ETC.

0	0	1	_____	KONDENSATORENTLADUNG BAUSTAHL MIT GEWINDE
0	0	2	_____	KONDENSATORENTLADUNG EDELSTAHL MIT GEWINDE
0	0	3	_____	KONDENSATORENTLADUNG Al Mg3 MIT GEWINDE
0	0	4	_____	KONDENSATORENTLADUNG 99,5% ALUMINIUM MIT GEWINDE
0	0	5	_____	KONDENSATORENTLADUNG MESSING MIT GEWINDE
0	1	1	_____	KONDENSATORENTLADUNG BAUSTAHL OHNE GEWINDE
0	1	2	_____	KONDENSATORENTLADUNG EDELSTAHL OHNE GEWINDE
0	1	3	_____	KONDENSATORENTLADUNG Al Mg3 OHNE GEWINDE
0	1	4	_____	KONDENSATORENTLADUNG 99,5% ALUMINIUM OHNE GEWINDE
0	1	5	_____	KONDENSATORENTLADUNG MESSING OHNE GEWINDE
0	1	6	_____	KONDENSATORENTLADUNG WEICHSTAHL NAGELBOLZEN
0	1	7	_____	KONDENSATORENTLADUNG EDELSTAHL NAGELBOLZEN
0	1	8	_____	KONDENSATORENTLADUNG Al Mg3 NAGELBOLZEN
0	1	9	_____	KONDENSATORENTLADUNG NAGELBOLZEN
0	2	1	_____	KONDENSATORENTLADUNG BAUSTAHL INNENGEWINDE
0	2	2	_____	KONDENSATORENTLADUNG EDELSTAHL INNENGEWINDE
0	2	3	_____	KONDENSATORENTLADUNG Al Mg3 INNENGEWINDE
0	2	4	_____	KONDENSATORENTLADUNG 99,5% ALUMINIUM INNENGEWINDE
0	2	5	_____	KONDENSATORENTLADUNG MESSING INNENGEWINDE

## BESTELLUNGSBEISPIEL

- 1) BESTELLUNG: M5 X 10 BAUSTAHL KONDENSATORENTLADUNGSBOLZEN MIT GEWINDE  
 BENUTZEN SIE FOLGENDEN CODE: **001-005-010**

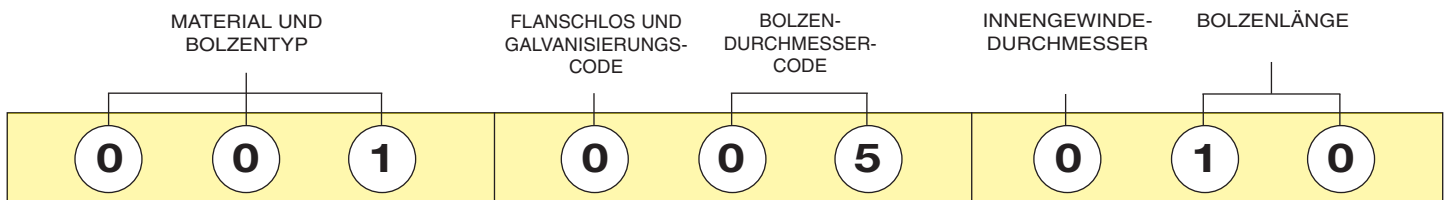

- 2) BESTELLUNG: 6MM X 30 EDELSTAHL KONDENSATORENTLADUNGSBOLZEN OHNE GEWINDE  
 BENUTZEN SIE FOLGENDEN CODE: **012-006-030**

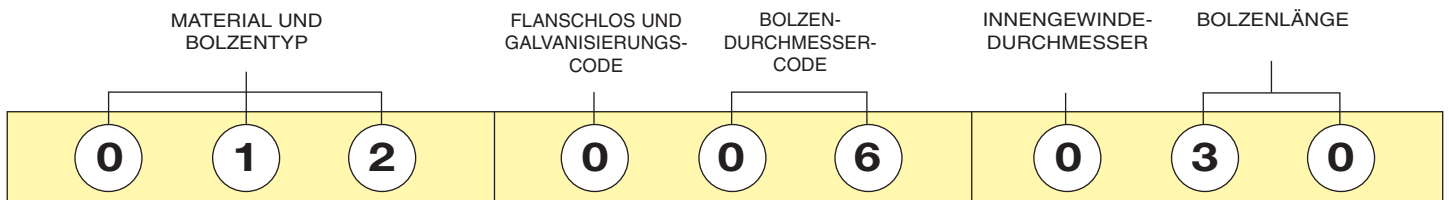

- 3) BESTELLUNG: M4 X 6 X 20 ALUMINIUMLEGIERUNG (Al Mg3) KONDENSATORENTLADUNGSBOLZEN MIT INNENGEWINDE  
 BENUTZEN SIE FOLGENDEN CODE: **023-006-420**

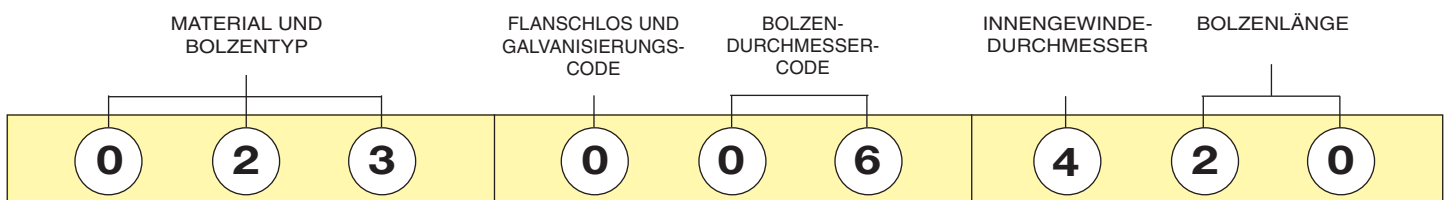

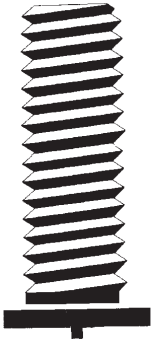

**CAPACITOR DISCHARGE MILD STEEL THREADED**  
**GOUJONS A SOUDER PAR DECHARGE DE CONDENSATEUR**  
**ACERO SUAVE ROSCADO – DESCARGA DE CONDENSADOR**  
**KONDENSATORENTLADUNG BAUSTAHL MIT GEWINDE**

SIZE	TAILLE	PART NO	NUMERO DE SERIE	WEIGHT PER 1000	POIDS POUR 1000	SIZE	TAILLE	PART NO	NUMERO DE SERIE	WEIGHT PER 1000	POIDS POUR 1000
DIMENSIONES	GRÖßE	PIEZA NO	TEIL NR	PESO POR CADA 1000	GEWICHT PRO 1000	DIMENSIONES	GRÖßE	PIEZA NO	TEIL NR	PESO POR CADA 1000	GEWICHT PRO 1000
▲ M3 x 6		001-003-006		0.330		▲ M5 x 16		001-005-016		2.075	
▲ M3 x 8		001-003-008		0.420		▲ M5 x 20		001-005-020		2.550	
▲ M3 x 10		001-003-010		0.492		▲ M5 x 25		001-005-025		3.150	
▲ M3 x 12		001-003-012		0.540		▲ M5 x 30		001-005-030		3.750	
▲ M3 x 16		001-003-016		0.680		▲ M5 x 35		001-005-035		4.350	
▲ M3 x 20		001-003-020		0.820		▲ M5 x 40		001-005-040		4.920	
▲ M3 x 25		001-003-025		0.980		▲ M5 x 45		001-005-045		5.520	
▲ M3 x 30		001-003-030		1.140		▲ M5 x 50		001-005-050		6.150	
▲ M3 x 35		001-003-035		1.300		▲ M6 x 8		001-006-008		1.600	
▲ M3 x 40		001-003-040		1.460		▲ M6 x 10		001-006-010		1.850	
△ M3 x 45		001-003-045		1.620		▲ M6 x 12		001-006-012		2.100	
△ M3 x 50		001-003-050		1.780		▲ M6 x 16		001-006-016		2.750	
▲ M4 x 6		001-004-006		0.500		▲ M6 x 20		001-006-020		3.400	
▲ M4 x 8		001-004-008		0.670		▲ M6 x 25		001-006-025		4.150	
▲ M4 x 10		001-004-010		0.800		▲ M6 x 30		001-006-030		4.900	
▲ M4 x 12		001-004-012		0.950		▲ M6 x 35		001-006-035		5.650	
▲ M4 x 16		001-004-016		1.180		▲ M6 x 40		001-006-040		6.400	
▲ M4 x 20		001-004-020		1.540		▲ M6 x 45		001-006-045		7.200	
▲ M4 x 25		001-004-025		1.920		▲ M6 x 50		001-006-050		7.950	
▲ M4 x 30		001-004-030		2.300		▲ M6 x 55		001-006-055		8.700	
▲ M4 x 35		001-004-035		2.650		▲ M6 x 60		001-006-060		9.450	
▲ M4 x 40		001-004-040		3.000							
▲ M4 x 45		001-004-045		3.350							
▲ M4 x 50		001-004-050		3.700							
▲ M5 x 8		001-005-008		1.150							
▲ M5 x 10		001-005-010		1.350							
▲ M5 x 12		001-005-012		1.600							

**RANGE CONTINUED OVERLEAF**  
**SUITE PAGE SUIVANTE**  
**PASA A LA PAGINA SIGUIENTE**  
**DIE AUSWAHL WIRD AUF DER**  
**FOLGENDEN SEITE FORTGESETZT**

▲ NORMALLY HELD IN STOCK  
 △ MANUFACTURED TO CUSTOMERS ORDER

▲ NORMALEMENT DISPONIBLE DE STOCK  
 △ FABRIQUE SELON LA COMMANDE DU CLIENT

▲ EN EXISTENCIAS, POR LO GENERAL  
 △ FABRICADO ESPECIALMENTE A PEDIDO DEL CLIENTE

▲ NORMALERWEISE AUF LAGER  
 △ PRODUZIERT NACH KUNDENAUFTRAG

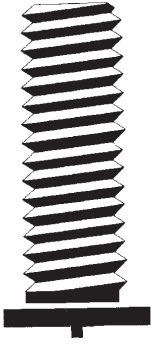

**CAPACITOR DISCHARGE MILD STEEL THREADED**  
**GOUJONS A SOUDER PAR DECHARGE DE CONDENSATEUR**  
**ACERO SUAVE ROSCADO – DESCARGA DE CONDENSADOR**  
**KONDENSATORENTLADUNG BAUSTAHL MIT GEWINDE**

SIZE	TAILLE	PART NO	NUMERO DE SERIE	WEIGHT PER 1000	POIDS POUR 1000
DIMENSIONES	GRÖÖE	PIEZA NO	TEIL NR	PESO POR CADA 1000	GEWICHT PRO 1000
▲ M8 x 10		001-008-010		3.310	
▲ M8 x 12		001-008-012		3.840	
▲ M8 x 16		001-008-016		4.900	
▲ M8 x 20		001-008-020		6.500	
▲ M8 x 25		001-008-025		8.130	
▲ M8 x 30		001-008-030		9.800	
▲ M8 x 35		001-008-035		11.400	
▲ M8 x 40		001-008-040		13.050	
▲ M8 x 45		001-008-045		14.700	
▲ M8 x 50		001-008-050		16.350	
△ M10 x 12		001-010-012			
△ M10 x 16		001-010-016			
△ M10 x 20		001-010-020			
△ M10 x 25		001-010-025			
△ M10 x 30		001-010-030			
△ M10 x 35		001-010-035			
△ M10 x 40		001-010-040			
△ M10 x 45		001-010-045			
△ M10 x 50		001-010-050			
△ M10 x 55		001-010-055			

FASTENING HANDLES TO PAN LIDS HAS TO BE CARRIED OUT HYGIENICALLY – AND WITHOUT ALLOWING OPPORTUNITIES FOR LEAKS TO APPEAR. SIMPLE SINGLE SIDE ASSEMBLY USING TAYLOR STUDWELDING TO WELD ONE STUD IN THE CENTRE OF THE PAN LID WAS THE EFFECTIVE SOLUTION.

LA FIXATION DES POIGNEES AUX COUVERCLES DE CASSEROLES DOIT ETRE EFFECTUEE DE MANIERE HYGIENIQUE ET SANS QU'IL Y AIT POSSIBILITE DE FUITES. L'ASSEMBLAGE FACILE D'UN SEUL COTE AU MOYEN D'UN GOUJON A SOUDER DE TAYLOR STUDWELDING AU CENTRE DU COUVERCLE DE LA CASSEROLE A ETE LA SOLUTION EFFICACE.

LAS ASAS DE LAS TAPAS DE CAZUELAS DEBEN PEGARSE DE FORMA HIGIENICA Y EVITANDO LA POSIBILIDAD DE FUGAS. LA SOLUCION MAS EFICAZ CONSISTE EN UN ENSAMBLAJE SIMPLE POR UN SOLO LADO EMPLEANDO EL SISTEMA TAYLOR STUDWELDING PARA SOLDAR UN ESPARRAGO EN EL CENTRO DE LA TAPA.

DIE BEFESTIGUNG VON GRIFFEN AN TOPFDECKELN MUÖ AUF HYGIENISCHE WEISE ERFOLGEN – UND OHNE DAB DABEI FLÜSSIGKEIT EINTWEICHEN KANN. EINFACHE EINSEITIGE MONTAGE MIT TAYLOR-BOLZENSCHWEIÖEN. EIN BOLZEN WIRD IN DIE MITTE DES TOPFDECKELS EINGESCHWEIÖT EINE EFFEKTIVE LÖSUNG.

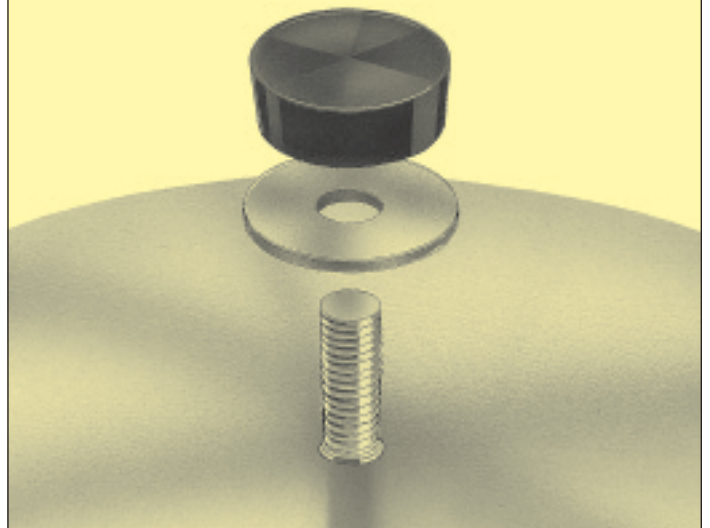

▲ NORMALLY HELD IN STOCK

△ MANUFACTURED TO CUSTOMERS ORDER

▲ NORMALEMENT DISPONIBLE DE STOCK

△ FABRIQUE SELON LA COMMANDE DU CLIENT

▲ EN EXISTENCIAS, POR LO GENERAL

△ FABRICADO ESPECIALMENTE A PEDIDO DEL CLIENTE

▲ NORMALERWEISE AUF LAGER

△ PRODUZIERT NACH KUNDENAUFTRAG

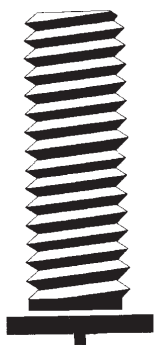

## CAPACITOR DISCHARGE STAINLESS STEEL THREADED GOUJONS A SOUDER C.D. FILETES EN ACIER INOXYDABLE ACERO INOXIDABLE ROSCADO – DESCARGA DE CONDENSADOR KONDENSATORENTLADUNG EDELSTAHL MIT GEWINDE

SIZE	TAILLE	PART NO	NUMERO DE SERIE	WEIGHT PER 1000	POIDS POUR 1000	SIZE	TAILLE	PART NO	NUMERO DE SERIE	WEIGHT PER 1000	POIDS POUR 1000
DIMENSIONES	GRÖÖE	PIEZA NO	TEIL NR	PESO POR CADA 1000	GEWICHT PRO 1000	DIMENSIONES	GRÖÖE	PIEZA NO	TEIL NR	PESO POR CADA 1000	GEWICHT PRO 1000
▲ M3 x 6		002-003-006		0.306		▲ M5 x 16		002-005-016		1.800	
▲ M3 x 8		002-003-008		0.380		▲ M5 x 20		002-005-020		2.410	
▲ M3 x 10		002-003-010		0.480		▲ M5 x 25		002-005-025		3.040	
▲ M3 x 12		002-003-012		0.550		▲ M5 x 30		002-005-030		3.630	
▲ M3 x 16		002-003-016		0.670		▲ M5 x 35		002-005-035		4.250	
▲ M3 x 20		002-003-020		0.886		▲ M5 x 40		002-005-040		4.850	
▲ M3 x 25		002-003-025		1.050		▲ M5 x 45		002-005-045		5.450	
▲ M3 x 30		002-003-030		1.214		▲ M5 x 50		002-005-050		6.050	
▲ M3 x 35		002-003-035		1.378		▲ M6 x 8		002-006-008		1.500	
▲ M3 x 40		002-003-040		1.542		▲ M6 x 10		002-006-010		1.866	
△ M3 x 45		002-003-045		1.706		▲ M6 x 12		002-006-012		2.250	
△ M3 x 50		002-003-050		1.870		▲ M6 x 16		002-006-016		2.650	
▲ M4 x 6		002-004-006		0.497		▲ M6 x 20		002-006-020		3.550	
▲ M4 x 8		002-004-008		0.650		▲ M6 x 25		002-006-025		4.400	
▲ M4 x 10		002-004-010		0.803		▲ M6 x 30		002-006-030		5.250	
▲ M4 x 12		002-004-012		0.950		▲ M6 x 35		002-006-035		6.050	
▲ M4 x 16		002-004-016		1.150		▲ M6 x 40		002-006-040		6.956	
▲ M4 x 20		002-004-020		1.570		▲ M6 x 45		002-006-045		7.800	
▲ M4 x 25		002-004-025		1.850		▲ M6 x 50		002-006-050		8.600	
▲ M4 x 30		002-004-030		2.200							
▲ M4 x 35		002-004-035		2.500							
▲ M4 x 40		002-004-040		2.800							
▲ M4 x 45		002-004-045		3.100							
▲ M4 x 50		002-004-050		3.400							
▲ M5 x 8		002-005-008		0.900							
▲ M5 x 10		002-005-010		1.279							
▲ M5 x 12		002-005-012		1.420							

**RANGE CONTINUED OVERLEAF  
SUITE PAGE SUIVANTE  
PASA A LA PAGINA SIGUIENTE  
DIE AUSWAHL WIRD AUF DER  
FOLGENDEN SEITE FORTGESETZT**

▲ NORMALLY HELD IN STOCK  
△ MANUFACTURED TO CUSTOMERS ORDER

▲ NORMALEMENT DISPONIBLE DE STOCK  
△ FABRIQUE SELON LA COMMANDE DU CLIENT

▲ EN EXISTENCIAS, POR LO GENERAL  
△ FABRICADO ESPECIALMENTE A PEDIDO DEL CLIENTE

▲ NORMALERWEISE AUF LAGER  
△ PRODUZIERT NACH KUNDENAUFTRAG

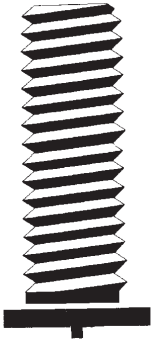

**CAPACITOR DISCHARGE STAINLESS STEEL THREADED**  
**GOUJONS A SOUDER C.D. FILETES EN ACIER INOXYDABLE**  
**ACERO INOXIDABLE ROSCADO – DESCARGA DE CONDENSADOR**  
**KONDENSATORENTLADUNG EDELSTAHL MIT GEWINDE**

SIZE	TAILLE	PART NO	NUMERO DE SERIE	WEIGHT PER 1000	POIDS POUR 1000	SIZE	TAILLE	PART NO	NUMERO DE SERIE	WEIGHT PER 1000	POIDS POUR 1000
DIMENSIONES	GRÖßE	PIEZA NO	TEIL NR	PESO POR CADA 1000	GEWICHT PRO 1000	DIMENSIONES	GRÖßE	PIEZA NO	TEIL NR	PESO POR CADA 1000	GEWICHT PRO 1000
▲ M8 x 10		002-008-010		3.330		△ M10 x 12		002-010-012			
▲ M8 x 12		002-008-012		3.964		△ M10 x 16		002-010-016			
▲ M8 x 16		002-008-016		5.232		△ M10 x 20		002-010-020			
▲ M8 x 20		002-008-020		6.500		△ M10 x 25		002-010-025			
▲ M8 x 25		002-008-025		8.000		△ M10 x 30		002-010-030			
▲ M8 x 30		002-008-030		9.600		△ M10 x 35		002-010-035			
▲ M8 x 35		002-008-035		11.200		△ M10 x 40		002-010-040			
▲ M8 x 40		002-008-040		12.700		△ M10 x 45		002-010-045			
▲ M8 x 45		002-008-045		14.200		△ M10 x 50		002-010-050			
▲ M8 x 50		002-008-050		15.800							

WHEN ATTACHING HYDRAULIC AND ELECTRICAL LINES, THE CONVENTIONAL METHOD OF DRILLING AND TAPPING WASTES IMPORTANT ON-SITE TIME. TAYLOR STUDWELDING ELIMINATES THE NEED FOR THIS AND PROVIDES A CLEAN, SECURE FINISH WITH NO LEAKAGE.

POUR ATTACHER DES CABLES HYDRAULIQUES ET ELECTRIQUES, LA METHODE TRADITIONNELLE DE PERCEGE ET TARAUDAGE PREND TROP DE TEMPS SUR PLACE. LES SYSTEMES TAYLOR STUDWELDING ELIMINENT CECI ET DONNENT UN FINI PROPRE, SUR ET SANS FUITE POSSIBLE.

EL METODO CONVENCIONAL PARA FIJAR LINEAS ELECTRICAS E HIDRAULICAS, QUE CONSISTE EN PERFORAR Y ROSCAR A PIE DE OBRA, CONSUME MUCHO TIEMPO. EL SISTEMA TAYLOR STUDWELDING ELIMINA ESA NECESIDAD, APORTANDO UNA FIJACION FIRME LIBRE DE FUGAS.

BEI DER BEFESTIGUNG VON HYDRAULISCHEN UND ELEKTRISCHEN LEITUNGEN VERSCHWENDET MAN BEI EINSATZ DER KONVENTIONELLEN BOHR – UND GEWINDE-SCHNEIDEMETHODE VIEL ZEIT. TAYLOR-BOLZENSCHWEIßEN ELIMINIERT DIE NOTWENDIGKEIT DIESER METHODEN UND LIEFERT SAUBERE UND SICHERE ARBEIT OHNE UNDICHTEN STELLEN.

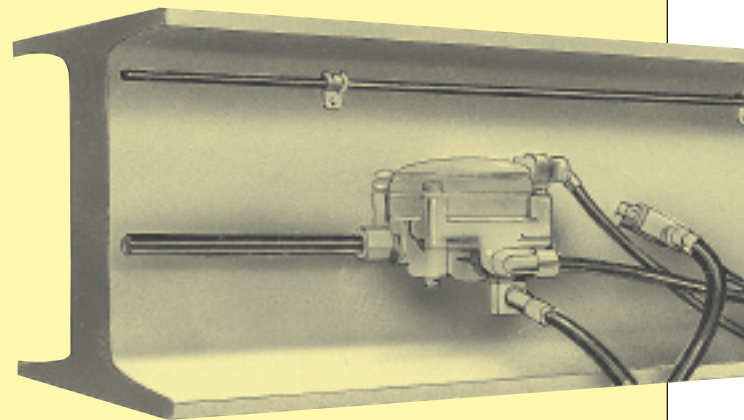

▲ NORMALLY HELD IN STOCK

△ MANUFACTURED TO CUSTOMERS ORDER

▲ NORMALEMENT DISPONIBLE DE STOCK

△ FABRIQUE SELON LA COMMANDE DU CLIENT

▲ EN EXISTENCIAS, POR LO GENERAL

△ FABRICADO ESPECIALMENTE A PEDIDO DEL CLIENTE

▲ NORMALERWEISE AUF LAGER

△ PRODUZIERT NACH KUNDENAUFTRAG

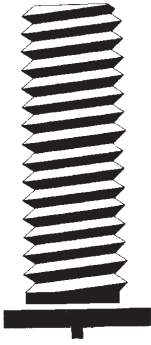

**CAPACITOR DISCHARGE AI Mg3 THREADED**

**GOJONS A SOUDER PAR DECHARGE DE CONDENSATEUR FILETES AI Mg3**

**AI Mg3 ROSCADO – DESCARGA DE CONDENSADOR**

**KONDENSATORENTLADUNG AI Mg3 MIT GEWINDE**

SIZE	TAILLE	PART NO	NUMERO DE SERIE	WEIGHT PER 1000	POIDS POUR 1000	SIZE	TAILLE	PART NO	NUMERO DE SERIE	WEIGHT PER 1000	POIDS POUR 1000
DIMENSIONES	GRÖÖE	PIEZA NO	TEIL NR	PESO POR CADA 1000	GEWICHT PRO 1000	DIMENSIONES	GRÖÖE	PIEZA NO	TEIL NR	PESO POR CADA 1000	GEWICHT PRO 1000
▲ M3 x 6		003-003-006		0.100		▲ M5 x 20		003-005-020		0.880	
▲ M3 x 8		003-003-008		0.130		▲ M5 x 25		003-005-025		1.000	
▲ M3 x 10		003-003-010		0.140		▲ M5 x 30		003-005-030		1.240	
▲ M3 x 12		003-003-012		0.150		▲ M5 x 35		003-005-035		1.420	
▲ M3 x 16		003-003-016		0.210		▲ M5 x 40		003-005-040		1.650	
▲ M3 x 20		003-003-020		0.290		▲ M5 x 45		003-005-045		1.850	
▲ M3 x 25		003-003-025		0.390		▲ M5 x 50		003-005-050		2.050	
▲ M3 x 30		003-003-030		0.473		▲ M6 x 8		003-006-008		0.460	
▲ M3 x 35		003-003-035		0.556		▲ M6 x 10		003-006-010		0.550	
▲ M3 x 40		003-003-040		0.639		▲ M6 x 12		003-006-012		0.700	
△ M3 x 45		003-003-045		0.722		▲ M6 x 16		003-006-016		0.944	
△ M3 x 50		003-003-050		0.805		▲ M6 x 20		003-006-020		1.187	
▲ M4 x 6		003-004-006		0.110		▲ M6 x 25		003-006-025		1.410	
▲ M4 x 8		003-004-008		0.180		▲ M6 x 30		003-006-030		1.700	
▲ M4 x 10		003-004-010		0.267		▲ M6 x 35		003-006-035		1.980	
▲ M4 x 12		003-004-012		0.320		▲ M6 x 40		003-006-040		2.337	
▲ M4 x 16		003-004-016		0.410		▲ M6 x 45		003-006-045		2.600	
▲ M4 x 20		003-004-020		0.500		▲ M6 x 50		003-006-050		2.850	
▲ M4 x 25		003-004-025		0.650		▲ M8 x 10		003-008-010		1.126	
▲ M4 x 30		003-004-030		0.766		▲ M8 x 12		003-008-012		1.331	
▲ M4 x 35		003-004-035		0.920		▲ M8 x 16		003-008-016		1.600	
▲ M4 x 40		003-004-040		1.070		▲ M8 x 20		003-008-020		2.150	
△ M4 x 45		003-004-045		1.220		▲ M8 x 25		003-008-025		2.650	
△ M4 x 50		003-004-050		1.370		▲ M8 x 30		003-008-030		3.239	
▲ M5 x 8		003-005-008		0.340		▲ M8 x 35		003-008-035		3.620	
▲ M5 x 10		003-005-010		0.400		▲ M8 x 40		003-008-040		4.090	
▲ M5 x 12		003-005-012		0.500		▲ M8 x 45		003-008-045		4.660	
▲ M5 x 16		003-005-016		0.690		▲ M8 x 50		003-008-050		5.120	

▲ NORMALLY HELD IN STOCK

▲ NORMALEMENT DISPONIBLE DE STOCK

▲ EN EXISTENCIAS, POR LO GENERAL

▲ NORMALERWEISE AUF LAGER

△ MANUFACTURED TO CUSTOMERS ORDER

△ FABRIQUE SELON LA COMMANDE DU CLIENT

△ FABRICADO ESPECIALMENTE A PEDIDO DEL CLIENTE

△ PRODUZIERT NACH KUNDENAUFTRAG

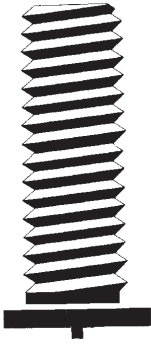

## CAPACITOR DISCHARGE AI 99.5 THREADED

GOJONS A SOUDER PAR DECHARGE  
DE CONDENSATEUR FILETES AI 99.5

## AI 99.5 ROSCADO – DESCARGA DE CONDENSADOR

## KONDENSATORENTLADUNG AI 99.5 MIT GEWINDE

SIZE	TAILLE	PART NO	NUMERO DE SERIE	WEIGHT PER 1000	POIDS POUR 1000	SIZE	TAILLE	PART NO	NUMERO DE SERIE	WEIGHT PER 1000	POIDS POUR 1000
DIMENSIONES	GRÖÖE	PIEZA NO	TEIL NR	PESO POR CADA 1000	GEWICHT PRO 1000	DIMENSIONES	GRÖÖE	PIEZA NO	TEIL NR	PESO POR CADA 1000	GEWICHT PRO 1000
△ M3 x 6		004-003-006		0.040		△ M5 x 20		004-005-020		0.880	
△ M3 x 8		004-003-008		0.080		△ M5 x 25		004-005-025		1.050	
△ M3 x 10		004-003-010		0.130		△ M5 x 30		004-005-030		1.250	
△ M3 x 12		004-003-012		0.160		△ M5 x 35		004-005-035		1.450	
△ M3 x 16		004-003-016		0.230		△ M5 x 40		004-005-040		1.640	
△ M3 x 20		004-003-020		0.300		△ M5 x 45		004-005-045		1.830	
△ M3 x 25		004-003-025		0.380		△ M5 x 50		004-005-050		2.020	
△ M3 x 30		004-003-030		0.460		△ M6 x 8		004-006-008		0.350	
△ M3 x 35		004-003-035		0.540		△ M6 x 10		004-006-010		0.500	
△ M3 x 40		004-003-040		0.620		△ M6 x 12		004-006-012		0.610	
△ M3 x 45		004-003-045		0.700		△ M6 x 16		004-006-016		0.910	
△ M3 x 50		004-003-050		0.780		△ M6 x 20		004-006-020		1.187	
△ M4 x 6		004-004-006		0.165		△ M6 x 25		004-006-025		1.400	
△ M4 x 8		004-004-008		0.200		△ M6 x 30		004-006-030		1.700	
△ M4 x 10		004-004-010		0.250		△ M6 x 35		004-006-035		2.000	
△ M4 x 12		004-004-012		0.300		△ M6 x 40		004-006-040		2.337	
△ M4 x 16		004-004-016		0.350		△ M6 x 45		004-006-045		2.590	
△ M4 x 20		004-004-020		0.440		△ M6 x 50		004-006-050		2.850	
△ M4 x 25		004-004-025		0.565		△ M8 x 10		004-008-010		1.126	
△ M4 x 30		004-004-030		0.690		△ M8 x 12		004-008-012		1.380	
△ M4 x 35		004-004-035		0.820		△ M8 x 16		004-008-016		1.740	
△ M4 x 40		004-004-040		0.950		△ M8 x 20		004-008-020		2.100	
△ M4 x 45		004-004-045		1.080		△ M8 x 25		004-008-025		2.600	
△ M4 x 50		004-004-050		1.210		△ M8 x 30		004-008-030		3.239	
△ M5 x 8		004-005-008		0.340		△ M8 x 35		004-008-035		3.600	
△ M5 x 10		004-005-010		0.430		△ M8 x 40		004-008-040		4.100	
△ M5 x 12		004-005-012		0.520		△ M8 x 45		004-008-045		4.600	
△ M5 x 16		004-005-016		0.700		△ M8 x 50		004-008-050		5.000	

▲ NORMALLY HELD IN STOCK

△ MANUFACTURED TO CUSTOMERS ORDER

▲ NORMALEMENT DISPONIBLE DE STOCK

△ FABRIQUE SELON LA COMMANDE DU CLIENT

▲ EN EXISTENCIAS, POR LO GENERAL

△ FABRICADO ESPECIALMENTE A PEDIDO DEL CLIENTE

▲ NORMALERWEISE AUF LAGER

△ PRODUZIERT NACH KUNDENAUFTRAG

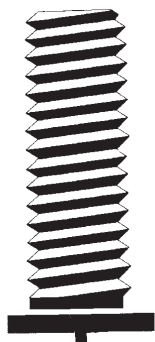

## CAPACITOR DISCHARGE BRASS THREADED

GOUJONS A SOUDER PAR DECHARGE  
DE CONDENSATEUR FILETES EN LAITON

## LATON ROSCADO – DESCARGA DE CONDENSADOR

## KONDENSATORENTLADUNG MESSING MIT GEWINDE

SIZE	TAILLE	PART NO	NUMERO DE SERIE	WEIGHT PER 1000	POIDS POUR 1000	SIZE	TAILLE	PART NO	NUMERO DE SERIE	WEIGHT PER 1000	POIDS POUR 1000
DIMENSIONES	GRÖÖE	PIEZA NO	TEIL NR	PESO POR CADA 1000	GEWICHT PRO 1000	DIMENSIONES	GRÖÖE	PIEZA NO	TEIL NR	PESO POR CADA 1000	GEWICHT PRO 1000
▲ M3 x 6		005-003-006		0.330		▲ M5 x 20		005-005-020		2.690	
▲ M3 x 8		005-003-008		0.420		▲ M5 x 25		005-005-025		3.300	
▲ M3 x 10		005-003-010		0.550		▲ M5 x 30		005-005-030		4.000	
▲ M3 x 12		005-003-012		0.680		▲ M5 x 35		005-005-035		4.640	
▲ M3 x 16		005-003-016		0.880		▲ M5 x 40		005-005-040		5.290	
▲ M3 x 20		005-003-020		1.190		▲ M5 x 45		005-005-045		5.940	
▲ M3 x 25		005-003-025		1.510		▲ M5 x 50		005-005-050		6.590	
▲ M3 x 30		005-003-030		1.830		▲ M6 x 8		005-006-008		1.620	
△ M3 x 35		005-003-035		2.150		▲ M6 x 10		005-006-010		2.025	
△ M3 x 40		005-003-040		2.470		▲ M6 x 12		005-006-012		2.350	
△ M3 x 45		005-003-045		2.790		▲ M6 x 16		005-006-016		2.920	
△ M3 x 50		005-003-050		3.110		▲ M6 x 20		005-006-020		3.795	
▲ M4 x 6		005-004-006		0.455		▲ M6 x 25		005-006-025		4.640	
▲ M4 x 8		005-004-008		0.670		▲ M6 x 30		005-006-030		5.550	
▲ M4 x 10		005-004-010		0.885		▲ M6 x 35		005-006-035		6.617	
▲ M4 x 12		005-004-012		1.100		▲ M6 x 40		005-006-040		7.400	
▲ M4 x 16		005-004-016		1.410		▲ M6 x 45		005-006-045		8.320	
▲ M4 x 20		005-004-020		1.700		▲ M6 x 50		005-006-050		9.190	
▲ M4 x 25		005-004-025		2.100		▲ M8 x 10		005-008-010		3.450	
▲ M4 x 30		005-004-030		2.436		▲ M8 x 12		005-008-012		3.960	
▲ M4 x 35		005-004-035		2.800		▲ M8 x 16		005-008-016		5.070	
▲ M4 x 40		005-004-040		3.140		▲ M8 x 20		005-008-020		6.690	
▲ M4 x 45		005-004-045		3.480		▲ M8 x 25		005-008-025		8.310	
▲ M4 x 50		005-004-050		3.820		▲ M8 x 30		005-008-030		9.940	
▲ M5 x 8		005-005-008		1.100		▲ M8 x 35		005-008-035		11.560	
▲ M5 x 10		005-005-010		1.385		▲ M8 x 40		005-008-040		13.180	
▲ M5 x 12		005-005-012		1.640		▲ M8 x 45		005-008-045		14.800	
▲ M5 x 16		005-005-016		2.026		▲ M8 x 50		005-008-050		16.420	

▲ NORMALLY HELD IN STOCK

▲ NORMALEMENT DISPONIBLE DE STOCK

▲ EN EXISTENCIAS, POR LO GENERAL

▲ NORMALERWEISE AUF LAGER

△ MANUFACTURED TO CUSTOMERS ORDER

△ FABRIQUE SELON LA COMMANDE DU CLIENT

△ FABRICADO ESPECIALMENTE A PEDIDO DEL CLIENTE

△ PRODUZIERT NACH KUNDENAUFTRAG





**CAPACITOR DISCHARGE MILD STEEL UNTHREADED**  
**GOUJONS A SOUDER PAR DECHARGE**  
**DE CONDENSATEUR LISSES EN ACIER DOUX**  
**ACERO DULCE SIN ROSCA – DESCARGA DE CONDENSADOR**  
**KONDENSATORENTLADUNG BAUSTAHL OHNE GEWINDE**

SIZE	TAILLE	PART NO	NUMERO DE SERIE	WEIGHT PER 1000	POIDS POUR 1000	SIZE	TAILLE	PART NO	NUMERO DE SERIE	WEIGHT PER 1000	POIDS POUR 1000
DIMENSIONES	GRÖÙE	PIEZA NO	TEIL NR	PESO POR CADA 1000	GEWICHT PRO 1000	DIMENSIONES	GRÖÙE	PIEZA NO	TEIL NR	PESO POR CADA 1000	GEWICHT PRO 1000
▲ 3mm x 6		011-003-006		0.330		▲ 5mm x 20		011-005-020		2.550	
▲ 3mm x 8		011-003-008		0.420		▲ 5mm x 25		011-005-025		3.150	
▲ 3mm x 10		011-003-010		0.492		▲ 5mm x 30		011-005-030		3.750	
▲ 3mm x 12		011-003-012		0.540		▲ 5mm x 35		011-005-035		4.350	
▲ 3mm x 16		011-003-016		0.680		▲ 5mm x 40		011-005-040		4.920	
▲ 3mm x 20		011-003-020		0.820		▲ 5mm x 45		011-005-045		5.520	
▲ 3mm x 25		011-003-025		0.980		▲ 5mm x 50		011-005-050		6.100	
▲ 3mm x 30		011-003-030		1.140		▲ 6mm x 8		011-006-008		1.600	
▲ 3mm x 35		011-003-035		1.300		▲ 6mm x 10		011-006-010		1.850	
▲ 3mm x 40		011-003-040		1.460		▲ 6mm x 12		011-006-012		2.100	
▲ 3mm x 45		011-003-045		1.620		▲ 6mm x 16		011-006-016		2.750	
▲ 3mm x 50		011-003-050		1.780		▲ 6mm x 20		011-006-020		3.400	
▲ 4mm x 8		011-004-008		0.670		▲ 6mm x 25		011-006-025		4.150	
▲ 4mm x 10		011-004-010		0.800		▲ 6mm x 30		011-006-030		4.900	
▲ 4mm x 12		011-004-012		0.950		▲ 6mm x 35		011-006-035		5.650	
▲ 4mm x 16		011-004-016		1.250		▲ 6mm x 40		011-006-040		6.400	
▲ 4mm x 20		011-004-020		1.540		▲ 6mm x 45		011-006-045		7.200	
▲ 4mm x 25		011-004-025		1.920		▲ 6mm x 50		011-006-050		7.950	
▲ 4mm x 30		011-004-030		2.300							
▲ 4mm x 35		011-004-035		2.650							
▲ 4mm x 40		011-004-040		3.000							
△ 4mm x 45		011-004-045		3.350							
△ 4mm x 50		011-004-050		3.700							
▲ 5mm x 8		011-005-008		1.150							
▲ 5mm x 10		011-005-010		1.350							
▲ 5mm x 12		011-005-012		1.600							
▲ 5mm x 16		011-005-016		2.070							

▲ NORMALLY HELD IN STOCK

△ MANUFACTURED TO CUSTOMERS ORDER

▲ NORMALEMENT DISPONIBLE DE STOCK

△ FABRIQUE SELON LA COMMANDE DU CLIENT

▲ EN EXISTENCIAS, POR LO GENERAL

△ FABRICADO ESPECIALMENTE A PEDIDO DEL CLIENTE

▲ NORMALERWEISE AUF LAGER

△ PRODUZIERT NACH KUNDENAUFTRAG



**CAPACITOR DISCHARGE STAINLESS STEEL UNTHREADED**  
**GOUJONS A SOUDER PAR DECHARGE**  
**DE CONDENSATEUR LISSES EN ACIER INOXYDABLES**  
**ACERO INOXIDABLE SIN ROSCA – DESCARGA DE CONDENSADOR**  
**KONDENSATORENTLADUNG EDELSTAHL OHNE GEWINDE**

SIZE	TAILLE	PART NO	NUMERO DE SERIE	WEIGHT PER 1000	POIDS POUR 1000	SIZE	TAILLE	PART NO	NUMERO DE SERIE	WEIGHT PER 1000	POIDS POUR 1000
DIMENSIONES	GRÖßE	PIEZA NO	TEIL NR	PESO POR CADA 1000	GEWICHT PRO 1000	DIMENSIONES	GRÖßE	PIEZA NO	TEIL NR	PESO POR CADA 1000	GEWICHT PRO 1000
▲ 3mm x 6		012-003-006		0.306		▲ 5mm x 25		012-005-025		3.040	
▲ 3mm x 8		012-003-008		0.380		▲ 5mm x 30		012-005-030		3.630	
▲ 3mm x 10		012-003-010		0.480		▲ 5mm x 35		012-005-035		4.250	
▲ 3mm x 12		012-003-012		0.550		▲ 5mm x 40		012-005-040		4.850	
▲ 3mm x 16		012-003-016		0.718		▲ 5mm x 45		012-005-045		5.450	
▲ 3mm x 20		012-003-020		0.886		▲ 5mm x 50		012-005-050		6.050	
▲ 3mm x 25		012-003-025		1.050		▲ 6mm x 8		012-006-008		1.476	
▲ 3mm x 30		012-003-030		1.253		▲ 6mm x 10		012-006-010		1.866	
▲ 3mm x 35		012-003-035		1.456		▲ 6mm x 12		012-006-012		2.250	
▲ 3mm x 40		012-003-040		1.659		▲ 6mm x 16		012-006-016		2.900	
▲ 3mm x 45		012-003-045		1.862		▲ 6mm x 20		012-006-020		3.550	
▲ 3mm x 50		012-003-050		2.065		▲ 6mm x 25		012-006-025		4.400	
▲ 4mm x 8		012-004-008		0.650		▲ 6mm x 30		012-006-030		5.250	
▲ 4mm x 10		012-004-010		0.803		▲ 6mm x 35		012-006-035		6.050	
▲ 4mm x 12		012-004-012		0.950		▲ 6mm x 40		012-006-040		6.956	
▲ 4mm x 16		012-004-016		1.260		▲ 6mm x 45		012-006-045		7.800	
▲ 4mm x 20		012-004-020		1.570		▲ 6mm x 50		012-006-050		8.600	
▲ 4mm x 25		012-004-025		1.850							
▲ 4mm x 30		012-004-030		2.200							
▲ 4mm x 35		012-004-035		2.500							
▲ 4mm x 40		012-004-040		2.800							
△ 4mm x 45		012-004-045		3.100							
△ 4mm x 50		012-004-050		3.400							
▲ 5mm x 8		012-005-008		0.900							
▲ 5mm x 10		012-005-010		1.279							
▲ 5mm x 12		012-005-012		1.420							
▲ 5mm x 16		012-005-016		1.920							
▲ 5mm x 20		012-005-020		2.410							

▲ NORMALLY HELD IN STOCK

▲ NORMALEMENT DISPONIBLE DE STOCK

▲ EN EXISTENCIAS, POR LO GENERAL

▲ NORMALERWEISE AUF LAGER

△ MANUFACTURED TO CUSTOMERS ORDER

△ FABRIQUE SELON LA COMMANDE DU CLIENT

△ FABRICADO ESPECIALMENTE A PEDIDO DEL CLIENTE

△ PRODUZIERT NACH KUNDENAUFTRAG

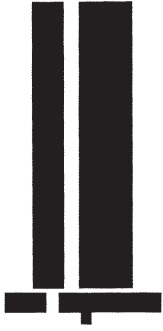

**CAPACITOR DISCHARGE AI Mg3 UNTHREADED**  
**GOUJONS A SOUDER PAR DECHARGE**  
**DE CONDENSATEUR LISSES AI Mg3**  
**AI Mg3 SIN ROSCA – DESCARGA DE CONDENSADOR**  
**KONDENSATORENTLADUNG AI Mg3 OHNE GEWINDE**

SIZE	TAILLE	PART NO	NUMERO DE SERIE	WEIGHT PER 1000	POIDS POUR 1000	SIZE	TAILLE	PART NO	NUMERO DE SERIE	WEIGHT PER 1000	POIDS POUR 1000
DIMENSIONES	GRÖßE	PIEZA NO	TEIL NR	PESO POR CADA 1000	GEWICHT PRO 1000	DIMENSIONES	GRÖßE	PIEZA NO	TEIL NR	PESO POR CADA 1000	GEWICHT PRO 1000
▲ 3mm x 6		013-003-006		0.140		▲ 5mm x 20		013-005-020		0.880	
▲ 3mm x 8		013-003-008		0.180		▲ 5mm x 25		013-005-025		1.000	
▲ 3mm x 10		013-003-010		0.220		▲ 5mm x 30		013-005-030		1.240	
▲ 3mm x 12		013-003-012		0.250		▲ 5mm x 35		013-005-035		1.420	
▲ 3mm x 16		013-003-016		0.325		▲ 5mm x 40		013-005-040		1.650	
▲ 3mm x 20		013-003-020		0.400		▲ 5mm x 45		013-005-045		1.830	
▲ 3mm x 25		013-003-025		0.500		▲ 5mm x 50		013-005-050		2.020	
▲ 3mm x 30		013-003-030		0.600		▲ 6mm x 8		013-006-008		0.400	
△ 3mm x 35		013-003-035		0.700		▲ 6mm x 10		013-006-010		0.550	
△ 3mm x 40		013-003-040		0.800		▲ 6mm x 12		013-006-012		0.700	
△ 3mm x 45		013-003-045		0.900		▲ 6mm x 16		013-006-016		0.943	
△ 3mm x 50		013-003-050		1.000		▲ 6mm x 20		013-006-020		1.187	
▲ 4mm x 8		013-004-008		0.320		▲ 6mm x 25		013-006-025		1.410	
▲ 4mm x 10		013-004-010		0.390		▲ 6mm x 30		013-006-030		1.700	
▲ 4mm x 12		013-004-012		0.450		▲ 6mm x 35		013-006-035		1.980	
▲ 4mm x 16		013-004-016		0.590		▲ 6mm x 40		013-006-040		2.337	
▲ 4mm x 20		013-004-020		0.720		▲ 6mm x 45		013-006-045		2.600	
▲ 4mm x 25		013-004-025		0.890		▲ 6mm x 50		013-006-050		2.850	
▲ 4mm x 30		013-004-030		1.050							
▲ 4mm x 35		013-004-035		1.220							
▲ 4mm x 40		013-004-040		1.380							
▲ 4mm x 45		013-004-045		1.540							
▲ 4mm x 50		013-004-050		1.700							
▲ 5mm x 8		013-005-008		0.340							
▲ 5mm x 10		013-005-010		0.400							
▲ 5mm x 12		013-005-012		0.500							
▲ 5mm x 16		013-005-016		0.690							

▲ NORMALLY HELD IN STOCK

▲ NORMALEMENT DISPONIBLE DE STOCK

▲ EN EXISTENCIAS, POR LO GENERAL

▲ NORMALERWEISE AUF LAGER

△ MANUFACTURED TO CUSTOMERS ORDER

△ FABRIQUE SELON LA COMMANDE DU CLIENT

△ FABRICADO ESPECIALMENTE A PEDIDO DEL CLIENTE

△ PRODUZIERT NACH KUNDENAUFTRAG



**CAPACITOR DISCHARGE AI 99.5 UNTHREADED**  
**GOUJONS A SOUDER PAR DECHARGE**  
**DE CONDENSATEUR LISSES AI 99.5**  
**AI 99.5 SIN ROSCA – DESCARGA DE CONDENSADOR**  
**KONDENSATORENTLADUNG AI 99.5 OHNE GEWINDE**

SIZE	TAILLE	PART NO	NUMERO DE SERIE	WEIGHT PER 1000	POIDS POUR 1000	SIZE	TAILLE	PART NO	NUMERO DE SERIE	WEIGHT PER 1000	POIDS POUR 1000
DIMENSIONES	GRÖßE	PIEZA NO	TEIL NR	PESO POR CADA 1000	GEWICHT PRO 1000	DIMENSIONES	GRÖßE	PIEZA NO	TEIL NR	PESO POR CADA 1000	GEWICHT PRO 1000
▲ 3mm x 6		014-003-006		0.140		▲ 5mm x 20		014-005-020		0.880	
▲ 3mm x 8		014-003-008		0.180		▲ 5mm x 25		014-005-025		1.000	
▲ 3mm x 10		014-003-010		0.220		▲ 5mm x 30		014-005-030		1.240	
▲ 3mm x 12		014-003-012		0.250		▲ 5mm x 35		014-005-035		1.420	
▲ 3mm x 16		014-003-016		0.325		▲ 5mm x 40		014-005-040		1.650	
▲ 3mm x 20		014-003-020		0.400		▲ 5mm x 45		014-005-045		1.830	
▲ 3mm x 25		014-003-025		0.500		▲ 5mm x 50		014-005-050		2.020	
▲ 3mm x 30		014-003-030		0.600		▲ 6mm x 8		014-006-008		0.400	
△ 3mm x 35		014-003-035		0.700		▲ 6mm x 10		014-006-010		0.550	
△ 3mm x 40		014-003-040		0.800		▲ 6mm x 12		014-006-012		0.700	
△ 3mm x 45		014-003-045		0.900		▲ 6mm x 16		014-006-016		0.943	
△ 3mm x 50		014-003-050		1.000		▲ 6mm x 20		014-006-020		1.187	
▲ 4mm x 8		014-004-008		0.320		▲ 6mm x 25		014-006-025		1.410	
▲ 4mm x 10		014-004-010		0.390		▲ 6mm x 30		014-006-030		1.700	
▲ 4mm x 12		014-004-012		0.450		▲ 6mm x 35		014-006-035		1.980	
▲ 4mm x 16		014-004-016		0.590		▲ 6mm x 40		014-006-040		2.337	
▲ 4mm x 20		014-004-020		0.720		▲ 6mm x 45		014-006-045		2.600	
▲ 4mm x 25		014-004-025		0.890		▲ 6mm x 50		014-006-050		2.850	
▲ 4mm x 30		014-004-030		1.050							
▲ 4mm x 35		014-004-035		1.220							
▲ 4mm x 40		014-004-040		1.380							
▲ 4mm x 45		014-004-045		1.540							
▲ 4mm x 50		014-004-050		1.700							
▲ 5mm x 8		014-005-008		0.340							
▲ 5mm x 10		014-005-010		0.400							
▲ 5mm x 12		014-005-012		0.500							
▲ 5mm x 16		014-005-016		0.690							

▲ NORMALLY HELD IN STOCK

▲ NORMALEMENT DISPONIBLE DE STOCK

▲ EN EXISTENCIAS, POR LO GENERAL

▲ NORMALERWEISE AUF LAGER

△ MANUFACTURED TO CUSTOMERS ORDER

△ FABRIQUE SELON LA COMMANDE DU CLIENT

△ FABRICADO ESPECIALMENTE A PEDIDO DEL CLIENTE

△ PRODUZIERT NACH KUNDENAUFTRAG



## CAPACITOR DISCHARGE BRASS UNTHREADED

GOUJONS A SOUDER PAR DECHARGE  
DE CONDENSATEUR LISSES EN LAITON

## LATON SIN ROSCA – DESCARGA DE CONDENSADOR

## KONDENSATORENTLADUNG MESSING OHNE GEWINDE

SIZE	TAILLE	PART NO	NUMERO DE SERIE	WEIGHT PER 1000	POIDS POUR 1000	SIZE	TAILLE	PART NO	NUMERO DE SERIE	WEIGHT PER 1000	POIDS POUR 1000
DIMENSIONES	GRÖßE	PIEZA NO	TEIL NR	PESO POR CADA 1000	GEWICHT PRO 1000	DIMENSIONES	GRÖßE	PIEZA NO	TEIL NR	PESO POR CADA 1000	GEWICHT PRO 1000
▲ 3mm x 6		015-003-006		0.140		▲ 5mm x 20		015-005-020		0.880	
▲ 3mm x 8		015-003-008		0.180		▲ 5mm x 25		015-005-025		1.000	
▲ 3mm x 10		015-003-010		0.220		▲ 5mm x 30		015-005-030		1.240	
▲ 3mm x 12		015-003-012		0.250		▲ 5mm x 35		015-005-035		1.420	
▲ 3mm x 16		015-003-016		0.325		▲ 5mm x 40		015-005-040		1.650	
▲ 3mm x 20		015-003-020		0.400		▲ 5mm x 45		015-005-045		1.830	
▲ 3mm x 25		015-003-025		0.500		▲ 5mm x 50		015-005-050		2.000	
▲ 3mm x 30		015-003-030		0.600		▲ 6mm x 8		015-006-008		0.428	
△ 3mm x 35		015-003-035		0.700		▲ 6mm x 10		015-006-010		0.550	
△ 3mm x 40		015-003-040		0.800		▲ 6mm x 12		015-006-012		0.700	
△ 3mm x 45		015-003-045		0.900		▲ 6mm x 16		015-006-016		0.944	
△ 3mm x 50		015-003-050		1.000		▲ 6mm x 20		015-006-020		1.187	
▲ 4mm x 8		015-004-008		0.320		▲ 6mm x 25		015-006-025		1.410	
▲ 4mm x 10		015-004-010		0.390		▲ 6mm x 30		015-006-030		1.700	
▲ 4mm x 12		015-004-012		0.450		▲ 6mm x 35		015-006-035		1.980	
▲ 4mm x 16		015-004-016		0.585		▲ 6mm x 40		015-006-040		2.337	
▲ 4mm x 20		015-004-020		0.720		▲ 6mm x 45		015-006-045		2.600	
▲ 4mm x 25		015-004-025		0.890		▲ 6mm x 50		015-006-050		2.850	
▲ 4mm x 30		015-004-030		1.050							
▲ 4mm x 35		015-004-035		1.220							
▲ 4mm x 40		015-004-040		1.380							
▲ 4mm x 45		015-004-045		1.550							
▲ 4mm x 50		015-004-050		1.710							
▲ 5mm x 8		015-005-008		0.340							
▲ 5mm x 10		015-005-010		0.400							
▲ 5mm x 12		015-005-012		0.500							
▲ 5mm x 16		015-005-016		0.690							

▲ NORMALLY HELD IN STOCK

▲ NORMALEMENT DISPONIBLE DE STOCK

▲ EN EXISTENCIAS, POR LO GENERAL

▲ NORMALERWEISE AUF LAGER

△ MANUFACTURED TO CUSTOMERS ORDER

△ FABRIQUE SELON LA COMMANDE DU CLIENT

△ FABRICADO ESPECIALMENTE A PEDIDO DEL CLIENTE

△ PRODUZIERT NACH KUNDENAUFTRAG



**CAPACITOR DISCHARGE MILD STEEL WELD NAIL**

**CLOUS A SOUDER PAR DECHARGE DE CONDENSATEUR EN ACIER DOUX**

**PUNTA DE AISLAMIENTO DE ACERO DULCE – DESCARGA DE CONDENSADOR**

**KONDENSATORENTLADUNG BAUSTAHL ISO-STIFT**

SIZE	TAILLE	PART NO	NUMERO DE SERIE	WEIGHT PER 1000	POIDS POUR 1000	SIZE	TAILLE	PART NO	NUMERO DE SERIE	WEIGHT PER 1000	POIDS POUR 1000
DIMENSIONES	GRÖßE	PIEZA NO	TEIL NR	PESO POR CADA 1000	GEWICHT PRO 1000	DIMENSIONES	GRÖßE	PIEZA NO	TEIL NR	PESO POR CADA 1000	GEWICHT PRO 1000
△ 3mm x 15		016-003-015		0.760		▲ 3mm x 150		016-005-150		8.220	
△ 3mm x 20		016-003-020		1.040		△ 3mm x 160		016-005-160		8.770	
△ 3mm x 25		016-003-025		1.310		△ 3mm x 185		016-005-185		9.595	
△ 3mm x 30		016-003-030		1.590		△ 3mm x 190		016-005-190		9.870	
△ 3mm x 35		016-003-035		1.865		△ 3mm x 200		016-005-200		10.420	
△ 3mm x 40		016-003-040		2.150		△ 3mm x 215		016-005-215		11.245	
△ 3mm x 45		016-003-045		2.425		△ 3mm x 300		016-005-300		15.920	
▲ 3mm x 50		016-003-050		2.700							
▲ 3mm x 55		016-003-055		2.975							
▲ 3mm x 60		016-003-060		3.260							
▲ 3mm x 65		016-003-065		3.535							
▲ 3mm x 70		016-003-070		3.810							
▲ 3mm x 75		016-004-075		4.085							
▲ 3mm x 80		016-004-080		4.360							
▲ 3mm x 85		016-004-085		4.635							
▲ 3mm x 90		016-004-090		4.920							
▲ 3mm x 95		016-004-095		5.195							
▲ 3mm x 100		016-004-100		5.470							
▲ 3mm x 105		016-004-105		5.745							
▲ 3mm x 110		016-004-110		6.020							
▲ 3mm x 115		016-004-115		6.295							
▲ 3mm x 120		016-004-120		6.570							
▲ 3mm x 125		016-004-125		6.845							
▲ 3mm x 130		016-005-130		7.120							
▲ 3mm x 135		016-005-135		7.395							
▲ 3mm x 140		016-005-140		7.670							
▲ 3mm x 145		016-005-145		7.945							

▲ NORMALLY HELD IN STOCK

▲ NORMALEMENT DISPONIBLE DE STOCK

▲ EN EXISTENCIAS, POR LO GENERAL

▲ NORMALERWEISE AUF LAGER

△ MANUFACTURED TO CUSTOMERS ORDER

△ FABRIQUE SELON LA COMMANDE DU CLIENT

△ FABRICADO ESPECIALMENTE A PEDIDO DEL CLIENTE

△ PRODUZIERT NACH KUNDENAUFTRAG



## CAPACITOR DISCHARGE STAINLESS STEEL WELD NAIL

### CLOUS A SOUDER PAR DECHARGE DE CONDENSATEUR EN ACIER INOXYDABLE

### PUNTA DE AISLAMIENTO DE ACERO INOXIDABLE – DESCARGA DE CONDENSADOR

### KONDENSATORENTLADUNG EDELSTAHL ISO-STIFT

SIZE	TAILLE	PART NO	NUMERO DE SERIE	WEIGHT PER 1000	POIDS POUR 1000
DIMENSIONES	GRÖÖE	PIEZA NO	TEIL NR	PESO POR CADA 1000	GEWICHT PRO 1000
△ 3mm x 15		017-003-015		0.760	
△ 3mm x 20		017-003-020		1.040	
△ 3mm x 25		017-003-025		1.320	
△ 3mm x 30		017-003-030		1.600	
△ 3mm x 35		017-003-035		1.880	
△ 3mm x 40		017-003-040		2.160	
△ 3mm x 45		017-003-045		2.440	
△ 3mm x 50		017-003-050		2.720	
△ 3mm x 55		017-003-055		3.000	
△ 3mm x 60		017-003-060		3.280	
△ 3mm x 65		017-003-065		3.560	
△ 3mm x 70		017-003-070		3.830	
△ 3mm x 75		017-003-075		4.110	
△ 3mm x 80		017-003-080		4.390	
△ 3mm x 85		017-003-085		4.670	
△ 3mm x 90		017-003-090		4.950	
△ 3mm x 95		017-003-095		5.230	
△ 3mm x 100		017-003-100		5.510	
△ 3mm x 105		017-003-105		5.790	
△ 3mm x 110		017-003-110		6.070	
△ 3mm x 115		017-003-115		6.350	
△ 3mm x 120		017-003-120		6.630	
△ 3mm x 125		017-003-125		6.910	
△ 3mm x 130		017-003-130		7.190	
△ 3mm x 135		017-003-135		7.470	
△ 3mm x 140		017-003-140		7.750	
△ 3mm x 145		017-003-145		8.030	
△ 3mm x 150		017-003-150		8.310	

TO FASTEN INSULATION TO METAL DUCTING WITHOUT DRILLING HOLES, TAYLOR STUDWELDING SUGGESTS WELDING A PIN DIRECT TO THE DUCTING. THE INSULATION IS THEN PUSHED ONTO THE PIN AND SAFELY SECURED BY A SPEED FIX WASHER. THUS, THE NEED FOR DRILLING AND BACK WELDING IS ELIMINATED.

POUR FIXER UN ISOLANT SUR DES CONDUITS METALLIQUES SANS PERCER DE TROUS, TAYLOR STUDWELDING SUGGERE DE SOUDER DIRECTEMENT UN CLOU SUR LE CONDUIT. L'ISOLANT PEUT ALORS ETRE POUSSE SUR LE CLOU ET FIXE FERMEMENT GRACE A UNE RONDELLE D'ARRET. DE CETTE MANIERE IL N'EST PLUS NECESSAIRE DE PERCER NI DE SOUDER PAR DERRIERE.

PARA FIJAR MATERIAL AISLANTE A CONDUCTOS DE METAL SIN REALIZAR PERFORACIONES, TAYLOR STUDWELDING RECOMIENDA SOLDADURA DE UN CLAVO DIRECTAMENTE AL CONDUCTO. SE PROCEDE LUEGO A PRESIONAR EL MATERIAL AISLANTE CONTRA LOS CLAVOS, FIJANDOLO RAPIDAMENTE CON ARANDELAS. DE ESTA FORMA SE ELIMINA LA NECESIDAD DE REALIZAR PERFORACIONES Y SOLDADURAS EN EL LADO POSTERIOR.

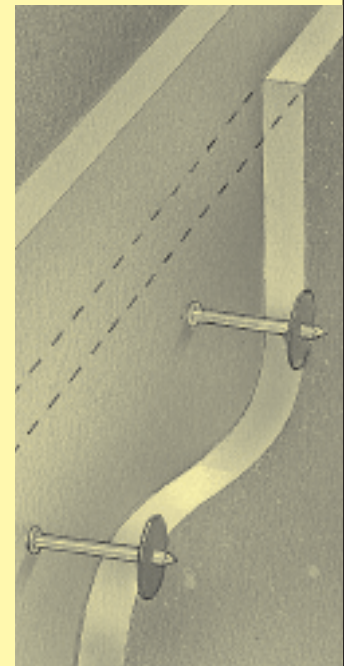

TAYLOR STUDWELDING SCHLÄGT VOR, ZUR FIXIERUNG VON ISOLIERUNGEN AN METALLSCHÄCHTEN STIFTE AUF DEN SCHACHT ZU SCHWEIÖEN. DABEI WERDEN KEINE LÖCHER GEBOHRT. DIE ISOLIERUNG WIRD AUF DEN STIFT GESCHOBEN UND MIT SCHNELLHALTERN BEFESTIGT. DAMIT ERÜBRIGT SICH DIE NOTWENDIGKEIT DES BOHRENS UND NACHRECHTSSCHWEIÖENS.

▲ NORMALLY HELD IN STOCK

△ MANUFACTURED TO CUSTOMERS ORDER

▲ NORMALEMENT DISPONIBLE DE STOCK

△ FABRIQUE SELON LA COMMANDE DU CLIENT

▲ EN EXISTENCIAS, POR LO GENERAL

△ FABRICADO ESPECIALMENTE A PEDIDO DEL CLIENTE

▲ NORMALERWEISE AUF LAGER

△ PRODUZIERT NACH KUNDENAUFTRAG



**CAPACITOR DISCHARGE AI Mg3 WELD NAIL**  
**GOUJONS A SOUDER PAR DECHARGE**  
**DE CONDENSATEUR AI Mg3**  
**CLAVOS DE AI Mg3 – DESCARGA DE CONDENSADOR**  
**KONDENSATORENTLADUNG AI Mg3 ISO-STIFE**

SIZE	TAILLE	PART NO	NUMERO DE SERIE	WEIGHT PER 1000	POIDS POUR 1000
DIMENSIONES	GRÖÖE	PIEZA NO	TEIL NR	PESO POR CADA 1000	GEWICHT PRO 1000
△ 3mm x 20		018-003-020		0.360	
△ 3mm x 25		018-003-025		0.450	
△ 3mm x 30		018-003-030		0.550	
△ 3mm x 40		018-003-040		0.740	
△ 3mm x 50		018-003-050		0.930	
△ 3mm x 60		018-003-060		1.120	
△ 3mm x 70		018-003-070		1.310	
△ 3mm x 80		018-003-080		1.500	
△ 3mm x 90		018-003-090		1.690	
△ 3mm x 100		018-003-100		1.990	
△ 3mm x 110		018-003-110		2.070	
△ 3mm x 120		018-003-120		2.260	
△ 3mm x 130		018-003-130		2.450	
△ 3mm x 140		018-003-140		2.650	
△ 3mm x 150		018-003-150		2.840	

IN THE FAST FOOD INDUSTRY, ENERGY CONSUMPTION HAS TO BE KEPT TO A MINIMUM TO MAINTAIN LOW OVERHEADS. CONSEQUENTLY, USING TAYLOR STUDWELDING TO ELIMINATE DISTORTION AND IMPROVE THE TRANSFER OF HEAT ON A RANGE IS AN EXCELLENT COST-EFFECTIVE SOLUTION.

DANS L'INDUSTRIE DES PLATS-MINUTE, LA CONSOMMATION D'ENERGIE DOIT ETRE TENUE A UN MINIMUM POUR MAINTENIR LES FRAIS GENERAUX AU PLUS BAS. PAR CONSEQUENT, L'UTILISATION DES GOUJONS TAYLOR STUDWELDING POUR ELIMINER LA DEFORMATION ET AMELIORER LE TRANSFERT DE CHALEUR SUR UNE CUISINIERE EST UNE SOLUTION EXCELLENTE DU POINT DE VUE DE LA RENTABILITE.

EN EL SECTOR DE COMIDAS PRECOCINADAS, EL CONSUMO ENERGETICO DEBE REDUCIRSE AL MINIMO PARA MANTENER UNOS GASTOS GENERALES BAJOS. POR TANTO, LA APLICACION DEL SISTEMA TAYLOR STUDWELDING CON OBJETO DE ELIMINAR LA DISTORSION Y MEJORAR LA CONDUCTIBILIDAD DE UN FOGON, REPRESENTA UNA SOLUCION CON RELACION COSTE-EFECTIVIDAD EXCELENTE.

IN DER SCHNELLIMBIßINDUSTRIE MUß DER ENERGIEVERBRAUCH AUF EINEM MINIMUM GEHALTEN WERDEN, UM DIE FESTAUSGABEN AUF EINEM NIEDRIGEN NIVEAU ZU HALTEN. DAHER IST DER EINSATZ DES TAYLOR-BOLZENSCHWEIßENS EINE EXZELLENT UND KOSTEN-EFFEKTIVE LÖSUNG, UM DIE WÄRMEDÄMMUNG DER ANLAGE ZU VERBESSERN.

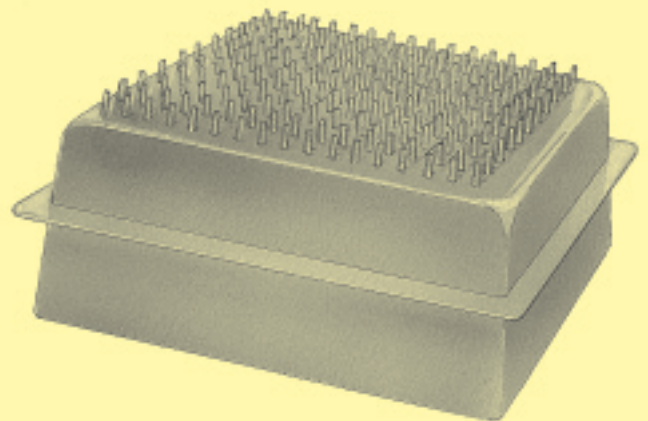

▲ NORMALLY HELD IN STOCK  
 △ MANUFACTURED TO CUSTOMERS ORDER

▲ NORMALEMENT DISPONIBLE DE STOCK  
 △ FABRIQUE SELON LA COMMANDE DU CLIENT

▲ EN EXISTENCIAS, POR LO GENERAL  
 △ FABRICADO ESPECIALMENTE A PEDIDO DEL CLIENTE

▲ NORMALERWEISE AUF LAGER  
 △ PRODUZIERT NACH KUNDENAUFTRAG



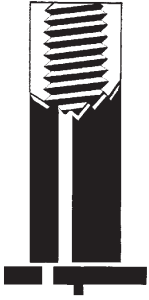

## CAPACITOR DISCHARGE MILD STEEL INTERNAL THREADED

## DOUILLES A SOUDER TARAUEES PAR DECHARGE DE CONDENSATEUR EN ACIER DOUX

## ACERO DULCE ROSCA INTERNA – DESCARGA DE CONDENSADOR

## KONDENSATORENTLADUNG BAUSTAHL INNENGEWINDE

\* PLEASE NOTE THE DIAMETER OF 8MM EXTERNAL MAY BE 7.1MM NOTIONAL

\* SE ADVIERTE QUE EL DIAMETRO EXTERNO DE 8MM EQUIVALE A 7.1MM DIAMETRO NOMINAL

\* VEUILLEZ NOTER QUE LE DIAMETRE DE 8MM EXTERNE EST 7.1MM FICTIF

\* BEMERKUNG: 8MM AUßENDURCHMESSER IST THEORETISCH 7.1MM

SIZE	TAILLE	PART NO	NUMERO DE SERIE	WEIGHT PER 1000	POIDS POUR 1000
DIMENSIONES	GRÖßE	PIEZA NO	TEIL NR	PESO POR CADA 1000	GEWICHT PRO 1000
▲ M3 x 5 x 8		021-005-308		0.890	
▲ M3 x 5 x 10		021-005-310		1.130	
▲ M3 x 5 x 12		021-005-312		1.370	
▲ M3 x 5 x 16		021-005-316		1.720	
▲ M3 x 5 x 20		021-005-320		2.320	
▲ M3 x 5 x 25		021-005-325		2.910	
▲ M3 x 5 x 30		021-005-330		3.500	
▲ M4 x 6 x 10		021-006-410		2.070	
▲ M4 x 6 x 12		021-006-412		2.510	
▲ M4 x 6 x 16		021-006-416		3.180	
▲ M4 x 6 x 20		021-006-420		4.280	
▲ M4 x 6 x 25		021-006-425		5.390	
▲ M4 x 6 x 30		021-006-430		6.400	
▲ M5 x 8 x 10*		021-008-510		3.300	
▲ M5 x 8 x 12*		021-008-512		3.900	
▲ M5 x 8 x 16*		021-008-516		5.200	
▲ M5 x 8 x 20*		021-008-520		6.500	
▲ M5 x 8 x 25*		021-008-525		8.100	
▲ M5 x 8 x 30*		021-008-530		9.800	
▲ M5 x 8 x 35*		021-008-535		11.600	
▲ M5 x 8 x 40*		021-008-540		13.000	

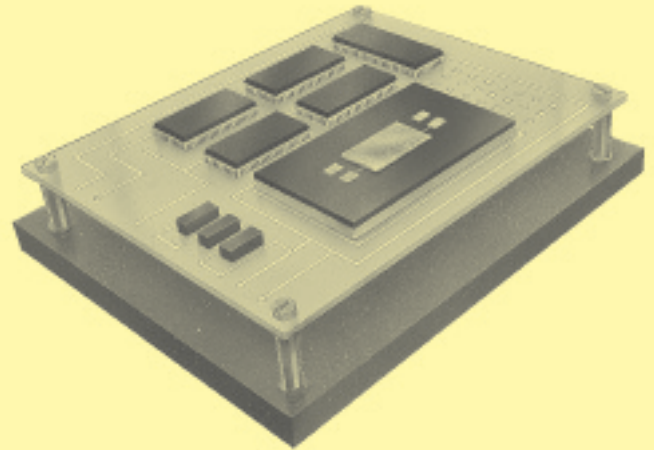

WITH THE PROLIFERATION OF PRINTED CIRCUIT BOARDS IN MODERN WELDING EQUIPMENT A METHOD TO MOUNT THEM WITHOUT REVERSE MARKING, DRILLING OR TAPPING WAS NEEDED.  
THE ANSWER?  
TAYLOR STUDWELDING TO WELD 4 TAPPED BOSSES AND MOUNT THE PCB SECURELY.

ETANT DONNE LE NOMBRE CROISSANT DE CIRCUITS IMPRIMES DANS L'EQUIPEMENT MODERNE DE SOUDAGE, IL FALLAIT UNE METHODE PERMETTANT DE LES MONTER SANS MARQUER L'ENVERS, SANS PERCER NI TARAUDER.  
LA REPOSE?  
TAYLOR STUDWELDING POUR SOUDER 4 DOUILLES TARAUEES ET MONTER LES CIRCUITS IMPRIMES FERMEMENT.

CON LA ENORME DIFUSION DE CIRCUITOS IMPRESOS EN EQUIPOS MODERNOS DE SOLDAR, SE NECESITA UN SISTEMA PARA MONTARLOS QUE NO DEJE MARCAS EN EL REVERSO Y NO REQUIERA LLEVAR A CABO PERFORACIONES Y ROSCADOS.  
EL SISTEMA TAYLOR STUDWELDING OFRECE LA SOLUCION, QUE CONSISTE EN SOLDAR 4 VASTAGOS CON ROSCA INTERNA PARA FIJAR FIRMEMENTE EL CIRCUITO IMPRESO.

MIT DER VERBREITUNG DER LEITERPLATTEN IN MODERNEN SCHWEIßGERÄTEN ERGAB SICH DIE NOTWENDIGKEIT, DIE PLATTEN OHNE MARKIERUNGEN, BOHREN ODER GEWINDESCHNEIDEN ANZUBRINGEN.  
DIE ANTWORT?  
TAYLOR BOLZENSCHWEIßEN – 4 GEWINDEBOLZEN WERDEN ANDESCHWEIßT UND DIE LEITERPLATTEN SICHER BEFESTIGT.

▲ NORMALLY HELD IN STOCK  
△ MANUFACTURED TO CUSTOMERS ORDER

▲ NORMALEMENT DISPONIBLE DE STOCK  
△ FABRIQUE SELON LA COMMANDE DU CLIENT

▲ EN EXISTENCIAS, POR LO GENERAL  
△ FABRICADO ESPECIALMENTE A PEDIDO DEL CLIENTE

▲ NORMALERWEISE AUF LAGER  
△ PRODUZIERT NACH KUNDENAUFTRAG

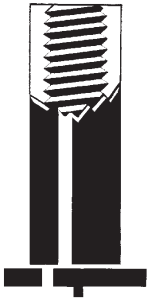

## CAPACITOR DISCHARGE STAINLESS STEEL INTERNAL THREADED

## DOUILLES A SOUDER TARAUEES PAR DECHARGE DE CONDENSATEUR EN ACIER INOXYDABLE

## ACERO INOXIDABLE ROSCA INTERNA – DESCARGA DE CONDENSADOR

## KONDENSATORENTLADUNG EDELSTAHL INNENGEWINDE

\* PLEASE NOTE THE DIAMETER OF 8MM EXTERNAL MAY BE 7.1MM NOTIONAL

\* SE ADVIERT QUE EL DIAMETRO EXTERNO DE 8MM EQUIVALE A 7.1MM DIAMETRO NOMINAL

\* VEUILLEZ NOTER QUE LE DIAMETRE DE 8MM EXTERNE EST 7.1MM FICTIF

\* BEMERKUNG: 8MM AUßENDURCHMESSER IST THEORETISCH 7.1MM

SIZE	TAILLE	PART NO	NUMERO DE SERIE	WEIGHT PER 1000	POIDS POUR 1000	SIZE	TAILLE	PART NO	NUMERO DE SERIE	WEIGHT PER 1000	POIDS POUR 1000
DIMENSIONES	GRÖßE	PIEZA NO	TEIL NR	PESO POR CADA 1000	GEWICHT PRO 1000	DIMENSIONES	GRÖßE	PIEZA NO	TEIL NR	PESO POR CADA 1000	GEWICHT PRO 1000
△ M3 x 5 x 10		022-005-310		1.940		△ M5 x 8 x 10*		022-008-510		3.980	
△ M3 x 5 x 12		022-005-312		2.240		△ M5 x 8 x 12*		022-008-512		4.590	
△ M3 x 5 x 16		022-005-316		2.830		△ M5 x 8 x 16*		022-008-516		5.820	
△ M3 x 5 x 20		022-005-320		3.430		△ M5 x 8 x 20*		022-008-520		7.040	
△ M3 x 5 x 25		022-005-325		4.180		△ M5 x 8 x 25*		022-008-525		8.570	
△ M3 x 5 x 30		022-005-330		4.920		△ M5 x 8 x 30*		022-008-530		10.100	
△ M4 x 6 x 10		022-006-410		2.810		△ M5 x 8 x 35*		022-008-535		11.630	
△ M4 x 6 x 12		022-006-412		3.240		△ M5 x 8 x 40*		022-008-540		13.160	
△ M4 x 6 x 16		022-006-416		4.100							
△ M4 x 6 x 20		022-006-420		4.970							
△ M4 x 6 x 25		022-006-425		6.050							
△ M4 x 6 x 30		022-006-430		7.130							

WHEN FIXING A SINK SECURELY INTO FITTED KITCHEN FURNITURE, 8 STUDS SHOULD BE WELDED AROUND THE RIM OF THE SINK TOP BEFORE SIMPLE FASTENING THROUGH THE SURFACE UNIT. THERE ARE NO BOLT HEADS SHOWING, NO REVERSE MARKINGS, JUST A CLEAN, HYGIENIC FINISH.

POUR FIXER FERMEMENT UN EVIER DANS UN BLOC DE CUISINE AMENAGEE, IL FAUT 8 GOUJONS SOUDES AUTOUR DU REBORD SUPERIEUR DE L'EVIER AVANT DE LES FIXER SIMPLEMENT A LA SURFACE DU MEUBLE. AUCUNE TETE DE BOULON N'EST APPARENTE, AUCUNE MARQUE, SEULEMENT UNE FINITION PROPRE ET HYGIENIQUE.

PARA FIJAR UN FREGADERO A UNA ENCIMERA DE COCINA, SE SUELDAN 8 ESPARRAGOS EN EL PERIMETRO DEL FREGADERO QUE ATRAVIESAN LA ENCIMERA. CON ELLO, NO QUEDAN A LA VISTA CABEZAS DE TORNO Y SE EVITAN LAS MARCAS EN EL REVERSO, LOGRANDOSE UN ACABADO LIMPIO E HIGIENICO.

FÜR DEN SICHEREN EINBAU EINES SPÜLBECKENS IN EINE FERTIGKÜCHE SOLLTEN 8 BOLZEN AM RAND DES SPÜLBECKENS ANGESCHWEIßT UND DANN EINFACH DURCH DIE ARBEITSPLATTE GESCHOBEN UND BEFESTIGT WERDEN. ES SIND KEINE BOLZENKÖPFE UND KEINE MARKIERUNGEN SICHTBAR. DER EINBAU IST SAUBER UND HYGIENISCH.

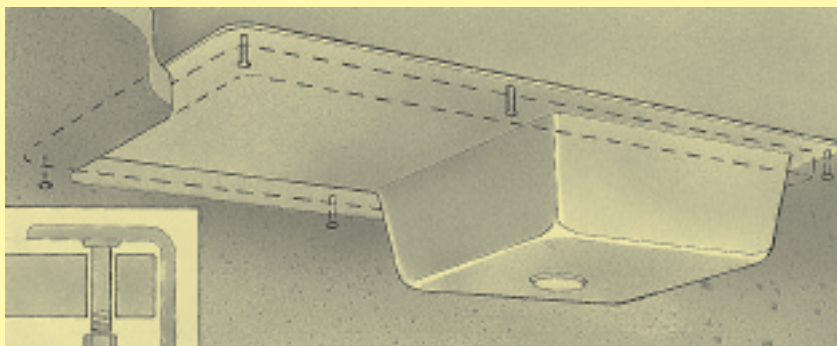

▲ NORMALLY HELD IN STOCK

▲ NORMALEMENT DISPONIBLE DE STOCK

▲ EN EXISTENCIAS, POR LO GENERAL

▲ NORMALERWEISE AUF LAGER

△ MANUFACTURED TO CUSTOMERS ORDER

△ FABRIQUE SELON LA COMMANDE DU CLIENT

△ FABRICADO ESPECIALMENTE A PEDIDO DEL CLIENTE

△ PRODUZIERT NACH KUNDENAUFTRAG

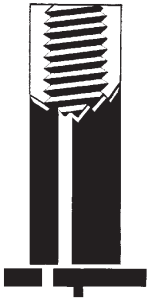

## CAPACITOR DISCHARGE AI Mg3 INTERNAL THREADED

## DOUILLES A SOUDER TARAUEDES PAR DECHARGE DE CONDENSATEUR EN AI Mg3

## AI Mg3 ROSCA INTERNA – DESCARGA DE CONDENSADOR

## KONDENSATORENTLADUNG AI Mg3 INNENGEWINDE

\* PLEASE NOTE THE DIAMETER OF 8MM EXTERNAL MAY BE 7.1MM NOTIONAL

\* SE ADVIERTE QUE EL DIAMETRO EXTERNO DE 8MM EQUIVALE A 7.1MM DIAMETRO NOMINAL

\* VEUILLEZ NOTER QUE LE DIAMETRE DE 8MM EXTERNE EST 7.1MM FICTIF

\* BEMERKUNG: 8MM AUßENDURCHMESSER IST THEORETISCH 7.1MM

SIZE	TAILLE	PART NO	NUMERO DE SERIE	WEIGHT PER 1000	POIDS POUR 1000
DIMENSIONES	GRÖßE	PIEZA NO	TEIL NR	PESO POR CADA 1000	GEWICHT PRO 1000
△ M3 x 5 x 8		023-005-308		0.590	
△ M3 x 5 x 10		023-005-310		0.700	
△ M3 x 5 x 12		023-005-312		0.800	
△ M3 x 5 x 16		023-005-316		1.010	
△ M3 x 5 x 20		023-005-320		1.230	
△ M3 x 5 x 25		023-005-325		1.490	
△ M3 x 5 x 30		023-005-330		1.760	
△ M4 x 6 x 10		023-006-410		1.010	
△ M4 x 6 x 12		023-006-412		1.150	
△ M4 x 6 x 16		023-006-416		1.460	
△ M4 x 6 x 20		023-006-420		1.770	
△ M4 x 6 x 25		023-006-425		2.160	
△ M4 x 6 x 30		023-006-430		2.550	
△ M5 x 8 x 10*		023-008-510		1.420	
△ M5 x 8 x 12*		023-008-512		1.640	
△ M5 x 8 x 16*		023-008-516		2.080	
△ M5 x 8 x 20*		023-008-520		2.510	
△ M5 x 8 x 25*		023-008-525		3.060	
△ M5 x 8 x 30*		023-008-530		3.600	
△ M5 x 8 x 35*		023-008-535		4.150	
△ M5 x 8 x 40*		023-008-540		4.700	

ATTACHING FEET TO THE BASE OF A KETTLE IS A SIMPLE PROCESS. USING TAYLOR STUDWELDING IT IS POSSIBLE TO WELD 3 STUDS TO THE KETTLE, GIVING A LEAKPROOF, QUALITY FINISH WITHOUT PIERCING THE BASE.

FIXER LES PIEDS A LA BASE D'UNE BOUILLLOIRE, NE PEUT ETRE PLUS SIMPLE. AVEC LES GOUJONS TAYLOR STUDWELDING IL EST POSSIBLE DE SOUDER 3 GOUJONS SUR LE FOND DE LA BOUILLLOIRE, DONNANT AINSI UN FINI DE QUALITE SANS POSSIBILITE DE FUITES ET SANS PERCER LE FOND.

FIJAR PIES A LA BASE DE UNA TETERA ELECTRICA ES UN PROCESO SIMPLE. EL SISTEMA TAYLOR STUDWELDING FACILITA LA SOLDADURA DE 3 ESPARRAGOS A LA CALDERA, SIN TENER QUE PERFORAR LA BASE, CON LO QUE SE LOGRA UN ACABADO DE ALTA CALIDAD A PRUEBA DE FUGAS.

DAS FIXIEREN VON FÜßEN AN HEIßWASSERKESSELN IST EINFACH. MIT DEM BOLZENSCHWEIßEN VON TAYLOR WERDEN AM KESSEL DREI FÜßE ANGESCHWEIßT – EINE EXZELLENT FERTIGUNG, OHNE DAß DABEI DER KESSELBODEN VERLETZT WIRD.



▲ NORMALLY HELD IN STOCK

▲ NORMALEMENT DISPONIBLE DE STOCK

▲ EN EXISTENCIAS, POR LO GENERAL

▲ NORMALERWEISE AUF LAGER

△ MANUFACTURED TO CUSTOMERS ORDER

△ FABRIQUE SELON LA COMMANDE DU CLIENT

△ FABRICADO ESPECIALMENTE A PEDIDO DEL CLIENTE

△ PRODUZIERT NACH KUNDENAUFTRAG

## SPEEDFIX WASHERS RONDELLES SPEEDFIX ARANDELAS DE FIJAR ISO-SCHEIBE

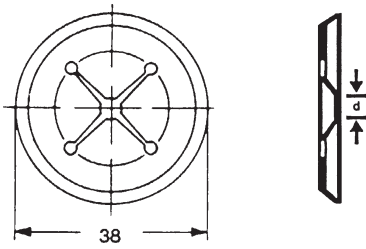

d(mm)	PART NO	NUMERO DE SERIE	WEIGHT PER 1000	POIDS POUR 1000	MATERIAL
	PIEZA NO	TEIL NR	PESO POR CADA 1000	GEWICHT PRO 1000	
▲ 3	061-003-038		3.50		MILD STEEL COATED ACIER DOUX RECOUVREMENT ZINC ACERO DULCE ZINCADO BAUSTAHL ISO-SCHEIBE VERZINKT
▲ 5	061-005-038		3.50		
▲ 6	061-006-038		3.50		
▲ 8	061-008-038		3.50		
▲ 3	061-003-039		3.50		STAINLESS STEEL ACIER INOXYDABLE ACERO INOXIDABLE EDELSTAHL
▲ 5	061-005-039		3.50		
▲ 6	061-006-039		3.50		
▲ 8	061-008-039		3.50		
▲ 3	061-003-041		3.50		BLACK SPRING STEEL ACIER ELASTIQUE NOIR ACERO CON ELASTICIDAD NEGRO FEDERSTAHL ISO-SCHEIBE SCHWARTZ
▲ 5	061-005-041		3.50		

## PLASTIC COATED SPEEDFIX WASHERS CLIP POUR CLOU D'ISOLATION RECOUVREMENT PLASTIQUE ARANDELA SPEEDFIX CUBIERTAS CON PLASTICO CLIPS FUR ISOLIERSTIFT KUNSTSTOFFUMMANTELT

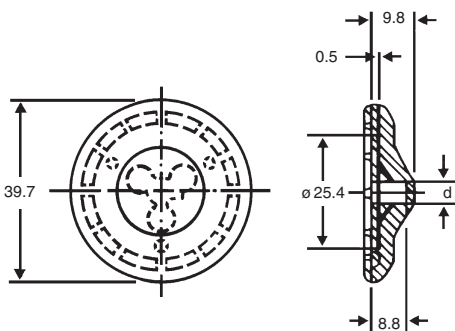

d(mm)	PART NO	BESTELL-Nr.
	NO DE PIECE	REFERENCIA
▲ 3	061-003-040	
▲ 5	061-005-040	
△ 6	061-006-040	

▲ NORMALLY HELD IN STOCK  
△ MANUFACTURED TO CUSTOMERS ORDER

▲ NORMALEMENT DISPONIBLE DE STOCK  
△ FABRIQUE SELON LA COMMANDE DU CLIENT

▲ EN EXISTENCIAS, POR LO GENERAL  
△ FABRICADO ESPECIALMENTE A PEDIDO DEL CLIENTE

▲ NORMALERWEISE AUF LAGER  
△ PRODUZIERT NACH KUNDENAUFTRAG

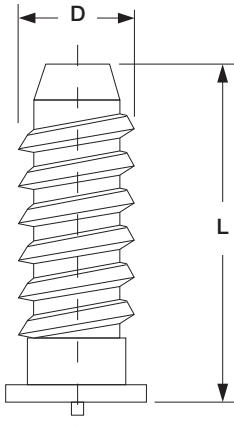
**MILD STEEL CAPACITOR DISCHARGE FIR TREE STUD****GOUJON SAPIN A SOUDER PAR DECHARGE  
DE CONDENSATEUR EN ACIER DOUX****PERNOS TIPO ABETO EN ACERO DULCE DESCARGA  
DE CONDENSADOR****KONDENSATORENLADUNG BAUSTAHL  
GROSSGEWINDEBOLZEN**

SIZE (D x L)	TAILLE (D x L)	PART NO	NUMERO DE SERIE	WEIGHT PER 1000	POIDS POUR 1000
DIMENSIONES (D x L)	GRÖÖE (D x L)	PIEZA NO	TEIL NR	PESO POR CADA 1000	GEWICHT PRO 1000
M5 x 9mm		009-005-005		1.01	
M5 x 14.2mm		009-005-002		1.60	
M5 x 14.5mm		009-005-001		1.70	
M5 x 16.5mm		009-005-003		2.00	
M5 x 25mm		009-005-004		2.70	

SIZE (D x L)	TAILLE (D x L)	PART NO	NUMERO DE SERIE	WEIGHT PER 1000	POIDS POUR 1000
DIMENSIONES (D x L)	GRÖÖE (D x L)	PIEZA NO	TEIL NR	PESO POR CADA 1000	GEWICHT PRO 1000
2.7 x 16mm		104-001-016		3.00	
2.7 x 19mm		104-001-019		3.40	
2.7 x 23mm		104-001-023		4.00	
2.7 x 25mm		104-001-025		4.10	
2.7 x 28mm		104-001-028		4.20	
2.7 x 32mm		104-001-032		4.50	
2.7 x 38mm		104-001-038		4.80	
2.7 x 42mm		104-001-042		5.00	
2.7 x 48mm		104-001-048		5.20	
2.7 x 52mm		104-001-052		5.30	
2.7 x 58mm		104-001-058		5.80	
2.7 x 62mm		104-001-062		6.00	
2.7 x 68mm		104-001-068		6.30	
2.7 x 72mm		104-001-072		6.50	
2.7 x 80mm		104-001-080		7.00	
2.7 x 90mm		104-001-090		7.50	
2.7 x 100mm		104-001-100		8.00	

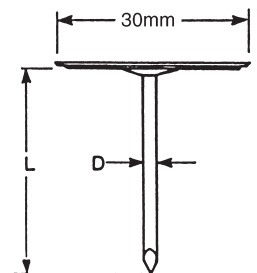
**CUP HEAD PINS****CLOU AVEC RONDELLE****CLAVOS CON ARANDELA FIJADA****TELLERSCHWEIÖSTIFTE**

▲ NORMALLY HELD IN STOCK

△ MANUFACTURED TO  
CUSTOMERS ORDER

▲ NORMALEMENT DISPONIBLE DE STOCK

△ FABRIQUE SELON LA COMMANDE DU  
CLIENT

▲ EN EXISTENCIAS, POR LO GENERAL

△ FABRICADO ESPECIALMENTE A PEDIDO  
DEL CLIENTE

▲ NORMALERWEISE AUF LAGER

△ PRODUZIERT NACH KUNDENAUFTRAG

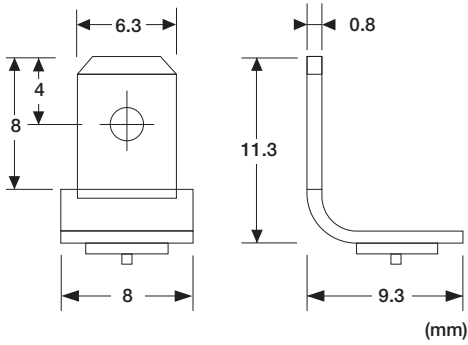

**CAPACITOR DISCHARGE EARTH TAGS**  
**COSES DE MISE A LA TERRE**  
**– A SOUDER PAR DECHARGE DE CONDENSATEUR**  
**TOMA A TIERRA – DESCARGA DE CONDENSADOR**  
**KONDENSATORENTLADUNG ERDUNGSSTECKER**

SIZE	TAILLE	PART NO	NUMERO DE SERIE	WEIGHT PER 1000	POIDS POUR 1000
DIMENSIONES	GRÖÖE	PIEZA NO	TEIL NR	PESO POR CADA 1000	GEWICHT PRO 1000
▲ CD-FS 63-6		061-001-001		0.980	
▲ CD-FS 63-1		061-001-002		1.100	
▲ CD-FS 63-4		061-001-003		0.500	
▲ CD-FS 63-2		061-001-004		1.100	

BRASS/LAITON/LATON/MESSING

STAINLESS STEEL/ACIER INOX./ACERO INOX./EDELSTAHL

Al Mg3/Al Mg3/Al Mg3/Al Mg3

MILD STEEL/ACIER DOUX/ACERO DULCE/BAUSTAHL

**CAPACITOR DISCHARGE MILD STEEL BRACKET**

**BRIDE DE FIXATION EN ACIER DOUX**  
**– DECHARGE DE CONDENSATEUR**

**SOPORTE DE ACERO DULCE**  
**– DESCARGA DE CONDENSADOR**

**KONDENSATORENTLADUNG BAUSTAHLHALTER**

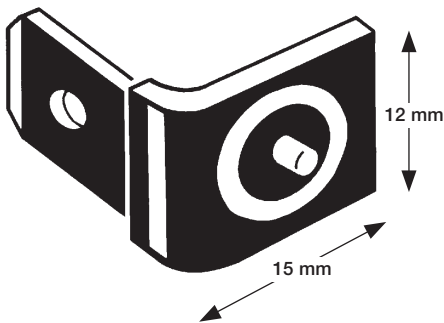

SIZE	TAILLE	PART NO	NUMERO DE SERIE	WEIGHT PER 1000	POIDS POUR 1000
DIMENSIONES	GRÖÖE	PIEZA NO	TEIL NR	PESO POR CADA 1000	GEWICHT PRO 1000
▲ 12 x 15		061-001-005		4.000	

▲ NORMALLY HELD IN STOCK

▲ NORMALEMENT DISPONIBLE DE STOCK

▲ EN EXISTENCIAS, POR LO GENERAL

▲ NORMALERWEISE AUF LAGER

△ MANUFACTURED TO CUSTOMERS ORDER

△ FABRIQUE SELON LA COMMANDE DU CLIENT

△ FABRICADO ESPECIALMENTE A PEDIDO DEL CLIENTE

△ PRODUZIERT NACH KUNDENAUFTRAG

### A TAYLORMADE SOLUTION TO SPECIAL SHAPES AND NON-STANDARD THREADED STUDS.

WITH COMPUTER AIDED DESIGN TECHNOLOGY AND THE INNOVATION TO LEAD THE FIELD IN STUDWELDING, TAYLOR STUDWELDING MANUFACTURES AND PROVIDES A WIDE RANGE OF SPECIAL SHAPE STUDS TO CUSTOMERS VERY OWN SPECIFICATIONS AND REQUIREMENTS.

SPEEDY DELIVERY IS ALSO AVAILABLE ON A LARGE RANGE OF NON-STANDARD THREADED FORMS, SOME OF WHICH ARE HELD IN STOCK, INCLUDING:-

2BA, 4BA, 6BA  
6/32 8/32 10/24 1/4 UNC 5/16 UNC  
IN A RANGE OF MATERIAL IE. MILD STEEL, STAINLESS STEEL AND AI Mg3.

TO OBTAIN THE ANSWER TO ANY SPECIAL SHAPES OR NON-STANDARD THREADED STUDS JUST CONTACT THE LEADERS IN THE FIELD AND DISCUSS YOUR REQUIREMENT TO FIND A 'TAYLORMADE' SOLUTION.

### UNE SOLUTION TAYLORMADE POUR S'ADAPTER AUX FORMES SPECIALES DES GOUJONS FILETES HORS STANDARD.

GRACE A LA CONCEPTION ASSISTEE PAR ORDINATEUR ET A L'INNOVATION A LA POINTE DE SON DOMAINE D'ACTIVITES DE SOUDAGE DE GOUJONS, TAYLOR STUDWELDING FABRIQUE ET FOURNIT UNE VASTE GAMME DE GOUJONS DE FORMES SPECIALES CONFORMEMENT AUX SPECIFICATIONS ET EXIGENCES PARTICULIERES DU CLIENT.

DES LIVRAISONS RAPIDES SONT AUSSI POSSIBLES POUR UNE GRANDE GAMME DE FILETAGES HORS STANDARD, DONT CERTAINS SONT TENUS EN STOCK, PAR EXEMPLE:

2BA, 4BA, 6BA  
6/32 8/32 10/24 1/4 UNC 5/16 UNC  
EN UNE GAMME DE MATERIAUX COMME PAR EXEMPLE: ACIER DOUX, ACIER INOXYDABLE ET AI Mg3

POUR OBTENIR LA SOLUTION POUR DES FORMES PARTICULIERES OU DES GOUJONS FILETES HORS STANDARD, VEUILLEZ CONTACTER LES LEADERS DU MARCHE ET EXPOSER VOS EXIGENCES POUR DECOUVRIR UNE SOLUTION "TAYLORMADE".

### TAYLOR STUDWELDING OFRECE SOLUCIONES A MEDIDA CON ESPARRAGOS DE FORMAS Y FILETEADOS ESPECIALES

GRACIAS AL DISEÑO ASISTIDO POR ORDENADOR Y MUCHAS INNOVACIONES, QUE LO HAN COLOCADO A LA CABEZA DEL SECTOR, TAYLOR STUDWELDING FABRICA Y DISTRIBUYE UNA AMPLIA GAMA DE ESPARRAGOS ESPECIALES QUE SE CONFORMAN A LAS EXIGENCIAS DEL CLIENTE Y SATISFACEN SUS REQUISITOS TECNICOS.

SE OFRECE UN SERVICIO DE ENTREGA RAPIDA DE UNA AMPLIA GAMA DE ESPARRAGOS CON FILETEADOS ESPECIALES, ALGUNOS DE LOS CUALES SE CUENTAN ENTRE NUESTRAS EXISTENCIAS DISPONIBLES, COMO PUEDEN SER:

2BA, 4BA, 6BA  
6/32, 8/32, 10/24, 1/4 UNC 5/16 UNC  
EN UNA GAMA DE MATERIALES DIVERSOS, COMO ACERO DULCE, ACERO INOXIDABLE Y AI Mg3

SI SUS REQUERIMIENTOS EXIGEN ESPARRAGOS CON FORMAS Y FILETEADOS ESPECIALES, SIMPLEMENTE CONSULTE CON EL LIDER EN LA MATERIA, TAYLOR STUDWELDING, QUE LE APORTARA UNA SOLUCION A LA MEDIDA.

### DIE TAYLOR-LÖSUNG FÜR SPEZIALFORMEN UND NICHTSTANDARDISIERTE BOLZEN MIT GEWINDE

CAD (COMPUTER AIDED DESIGN) -TECHNIK UND INNOVATION FÜHRTE ZU EINER FÜHRUNGSPPOSITION AUF DEM GEBIET DES BOLZENSCHWEIßENS. TAYLOR STUDWELDING PRODUZIERT UND LIEFERT EIN VIelfÄLTIGES ANGEBOT AN SPEZIALGEFORMTEN BOLZEN NACH DEN EIGENEN SPEZIFIKATIONEN UND ANFORDERUNGEN DES KUNDEN.

DARÜBERHINAUS IST FÜR EIN UMFASSENDES ANGEBOT AN NICHTSTANDARDISIERTEN FORMEN MIT GEWINDE EINE SCHNELLLIEFERUNG MÖGLICH. EINIGE DIESER FORMEN LIEGEN AUF LAGER, DAZU GEHÖREN:

2BA, 4BA, 6BA  
6/32 8/32 10/24 1/4 UNC 5/16 UNC  
IN VERSCHIEDENEN MATERIALIEN, Z.B. WEICHSTAHL, EDELSTAHL UND AI Mg3.

BENÖTIGEN SIE SPEZIALFORMEN ODER NICHTSTANDARDISIERTE BOLZEN MIT GEWINDE WENDEN SIE SICH EINFACH AN DEN MARKTFÜHRER AUF DEM GEBIET UND ÄÜßERN SIE IHRE WÜNSCHE. WIR FINDEN EINE MAßGESCHNEIDERTE LÖSUNG.

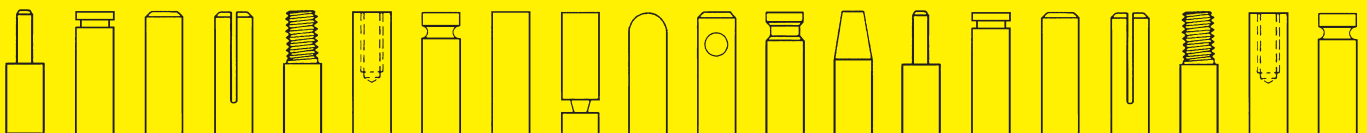

Taylor Studwelding Systems Limited has over 30 years professional experience in the industry, constantly developing its position as the UK's leading designer, manufacturer and supplier of studwelding equipment.



TAYLOR STUDWELDING SYSTEMS LIMITED  
COMMERCIAL ROAD, DEWSBURY, WEST YORKSHIRE, WF13 2BD, ENGLAND  
TEL: +44 (0)1924 452123 FAX: +44 (0)1924 430059  
email: [sales@taylor-studwelding.com](mailto:sales@taylor-studwelding.com) [www.taylor-studwelding.com](http://www.taylor-studwelding.com)