

# TAYLOR STUDWELDING SYSTEMS LIMITED.

OPERATING MANUAL  
FOR  
AUTO FEED ESCAPEMENT UNIT

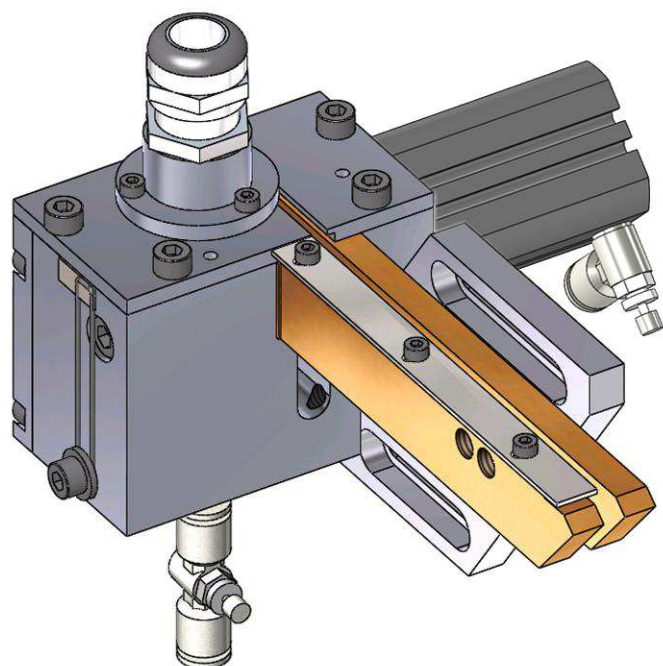

# **INDEX**

<b>PAGE</b>	<b>CONTENT</b>
<b>3</b>	<b>General information</b>
<b>5</b>	<b>Introduction</b>
<b>7</b>	<b>Safety</b>
<b>10</b>	<b>Setting up</b>
<b>16</b>	<b>Escapement component explosion</b>
<b>19</b>	<b>Pneumatic diagram</b>
<b>20</b>	<b>Accessories</b>
<b>23</b>	<b>EC declaration of conformity</b>

# **GENERAL INFORMATION**

## **MANUFACTURERS DETAILS**



**TAYLOR STUDWELDING SYSTEMS LIMITED  
COMMERCIAL ROAD  
DEWSBURY  
WEST YORKSHIRE  
WF13 2BD  
ENGLAND**

**TELEPHONE : +44 (0)1924 452123  
FACSIMILE : +44 (0)1924 430059  
e-mail : info@taylor-studwelding.com**





**TECHNICAL TEL : +44 (0)1924 487703  
SALES TEL : +44 (0)1924 487701**

## **PURPOSE AND CONTENT OF THIS MANUAL**

**This manual has been written for :**

-  **The operator of the welding machine.**
-  **The personnel of the final customer responsible for the installation and operation of the machine.**

**This manual contains information on :**

-  **Installation and connection**
-  **Operation.**
-  **Technical data.**
-  **Spare parts.**
-  **Accessories.**

# **GENERAL INFORMATION**

## **FURTHER INFORMATION**

Should you require additional technical information, please contact us directly (details on page 3) or our local agent / distributor (details of agents etc. can be obtained from us).

This manual contains important information which is a pre-requisite for safe operation of the equipment. The operating personnel must be able to consult this manual. In the interests of safety, make this manual available to your personnel in good time.

If the equipment is sold / passed on, please hand over this manual to the new owner. Please immediately inform us of the name and address of the new owner, in case we need to contact him regarding the safety of the device.



***Please read this manual carefully before installation of the machine.***



***Please especially observe the safety instructions.***

# **INTRODUCTION**

## **INTRODUCTION**

The complete range of Taylor Studwelding Systems Capacitor Discharge and Drawn Arc units are compact, portable Stud Welding equipments. The units are specifically designed to enable a small diameter range of ferrous and non-ferrous weld studs to be welded to light gauge, self-finish or pre-coated materials, and in the case of CD with little or no reverse marking.

The equipment consists of an automatic feed escapement for use with an auto feed welding pistol or SIK2 weld.

Two different processes are available: Capacitor Discharge (CD) and Drawn Arc (DA), these are outlined below.

## **THE PROCESS (CD)**

Capacitor Discharge stud welding is a form of welding in which the energy required for the welding process is derived from a bank of charged capacitors. This stored energy is discharged across the gap between the two surfaces to be welded as they are propelled towards each other. The arc produced heats the two surfaces, melting a thin film of metal on each surface and the propelling force closes the gap between the two faces, thus forming a weld.

In contact welding the stud to be welded is forced by spring pressure on to the plate. At this point the arc gap between the two components is maintained by a small pip on the welding face of the stud. On initiation of the high current pulse from the capacitors, this pip vaporises and an arc is drawn between the workpiece and the stud. The heat from this arc melts the base of the stud and the area of the work piece directly beneath the stud, whilst the spring pressure from the pistol accelerates the stud towards the workpiece. Within 3 to 4 milliseconds the stud hits the workpiece and the arc is extinguished. The kinetic energy contained in the moving stud and the remaining spring pressure, forge the molten parts together to form a weld.

# **INTRODUCTION**

## **THE PROCESS (DA)**

The Drawn Arc process is a long established, well proven method of stud welding. The pistol lifts the stud to be welded away from the workpiece, simultaneously striking an arc between the two. This causes both the stud and the workpiece to melt. After the pre-selected weld time has elapsed, the pistol returns the stud to the molten pool on the workpiece, thus forming the weld. The energy required to perform the weld is derived from a transformer - rectifier in the weld control unit.

Infinitely variable weld time allows for short cycle welding, with or without inert gas purging.

# **SAFETY**

## **PROTECT YOURSELF AND OTHERS !**

Read and understand these safety notices.

### **1. ELECTRICAL**

No portion of the outer cover of the welding controller should be removed by anyone other than suitably qualified personnel and never whilst mains power is connected. **ALWAYS** disconnect the mains plug from the socket.



## **RISK TO LIFE !!!**

**BE AWARE !** The CD equipment may contain a sealed power supply module which operates on high frequency inverter principles. Due to the potentially fatal voltages in this module we do not recommend tampering with the module. It can be safely removed and replaced via our factory exchange system.

**BE AWARE !** Capacitors store electrical energy. Check for residual charge before carrying out any internal maintenance.

**DO NOT !** use any fluids to clean electrical components as these may penetrate into the electrical system

Installation must be according to the setting up procedure detailed on pages 10 to 15 of this manual and must be in line with national, regional and local safety codes.

### **2. FIRE**

During welding small particles of very hot metal are expelled. Ensure that no combustible materials can be ignited by these.

# **SAFETY**

## **3. PERSONNEL SAFETY**

Arc rays can burn your eyes and skin and noise can damage your hearing.

Operators and personnel working in close proximity must wear suitable eye, ear and body protection.

Fumes and gases can seriously harm your health. Use the equipment only in a suitably ventilated area. If ventilation is inadequate, then appropriate fume extraction equipment must be used.

Hot metal spatter can cause fire and burns. Appropriate clothing must be worn.

Clothing made from, or soiled with, combustible materials must NOT be worn. Have a fire extinguisher nearby and know how to use it.

Magnetic fields from high currents can affect heart pacemakers or other electronically controlled medical devices. It is imperative that all personnel likely to come into the vicinity of any welding plant are warned of the possible RISK TO LIFE before entering the area.

## **4. MAINTENANCE**

All cables must be inspected regularly to ensure that no danger exists from worn or damaged insulation or from unsound electrical connections. Special note should be made of the cables close to the pistol, where maximum wear occurs.

As well as producing inconsistent welds, worn cables can overheat or spark, giving rise to the risk of fire.

## **5. TRAINING**

Use of the equipment must be limited to authorised personnel only who must be suitably trained and must have read and understood this manual. This manual must be made available to all operators at all times. Further copies of this manual may be purchased from the manufacturer. Measures must be taken to prevent the use of this equipment by unauthorised personnel.



# **SAFETY**

## **6. INSTALLATION**

Ensure that the site chosen for the equipment is able to support the weight of the equipment and that it will not fall or cause a danger in the course of its normal operation. Do not hang connecting cables over sharp edges and do not install connecting cables near heat sources or via traffic routes where people may trip over them or they may be damaged by the passage of vehicles (forklifts etc.).

## **7. INTERFERENCE**

During welding operations, intense magnetic and electrical fields are unavoidably produced and these may interfere with other sensitive electronic equipment.

All Taylor Studwelding equipment is designed, manufactured and tested to conform the current appropriate European standards and directives regarding electromagnetic emissions and immunity and as such is safe to use in any normal environment.

## **8. DISPOSAL**

The equipment either wholly or any of its component parts may be disposed of as part of general industrial waste or passed to a scrap merchant. Non of the components used in the manufacture are toxic, carcinogenic or harmful to health.

# SETTING UP

## SETTING UP THE BOWL & ESCAPEMENT

Setup the bowl feed & for the required stud diameter.

To change the bowl, undo the screw in the centre of the bowl, remove the bowl and replace with the correct one for the stud being used (see page 20 for a list suitable bowls).

bowl mounting screw

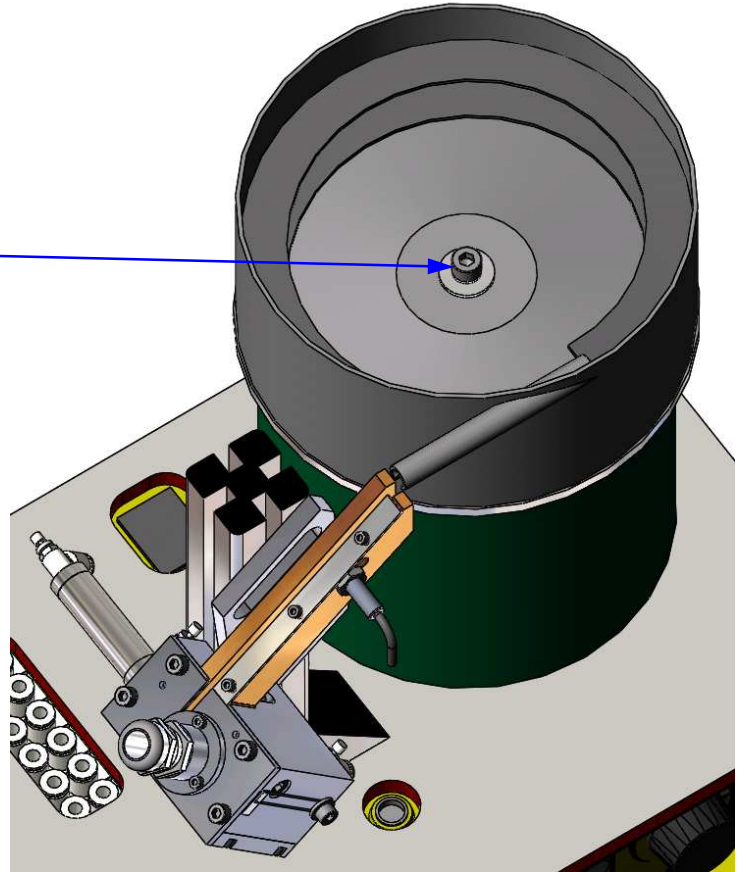

Align the output tube of the bowl with the track of the escapement and re-tighten the central screw.

If necessary loosen these 2 screws to move the position of the escapement.

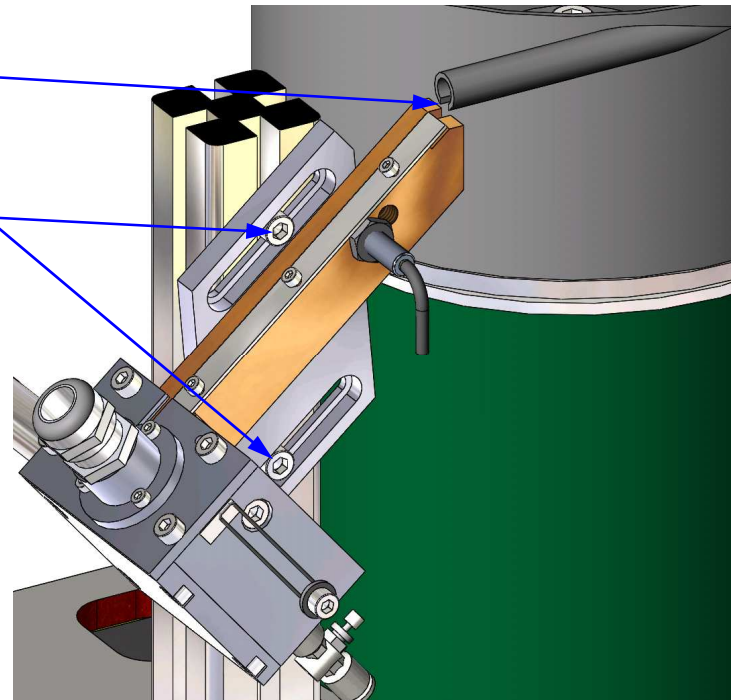

# SETTING UP

## SETTING UP THE BOWL & ESCAPEMENT

Setup the escapement for the required stud diameter.

To change the stud size, loosen the top nut of the feed hose gland and pull out the feed hose. Undo the 4 screws holding the top plate and remove the top plate complete with pipe holder and feed hose gland.

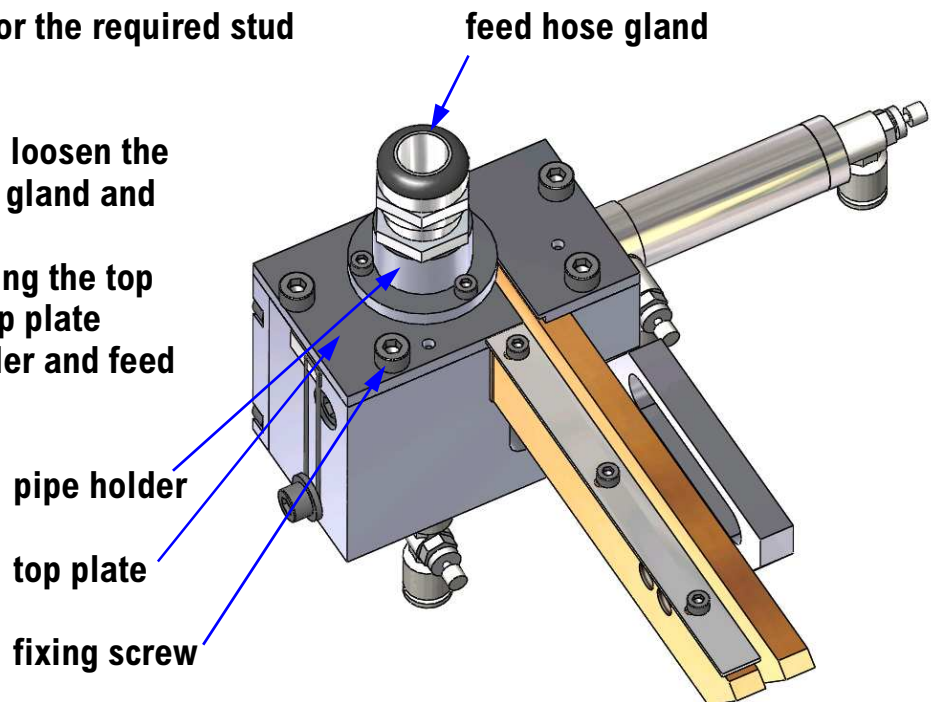

Ensure that the pneumatic shut-off valve is turned to off. Lift the transfer block out of the escapement. Loosen the gate spring retaining screw and move the spring aside, then withdraw the gate.

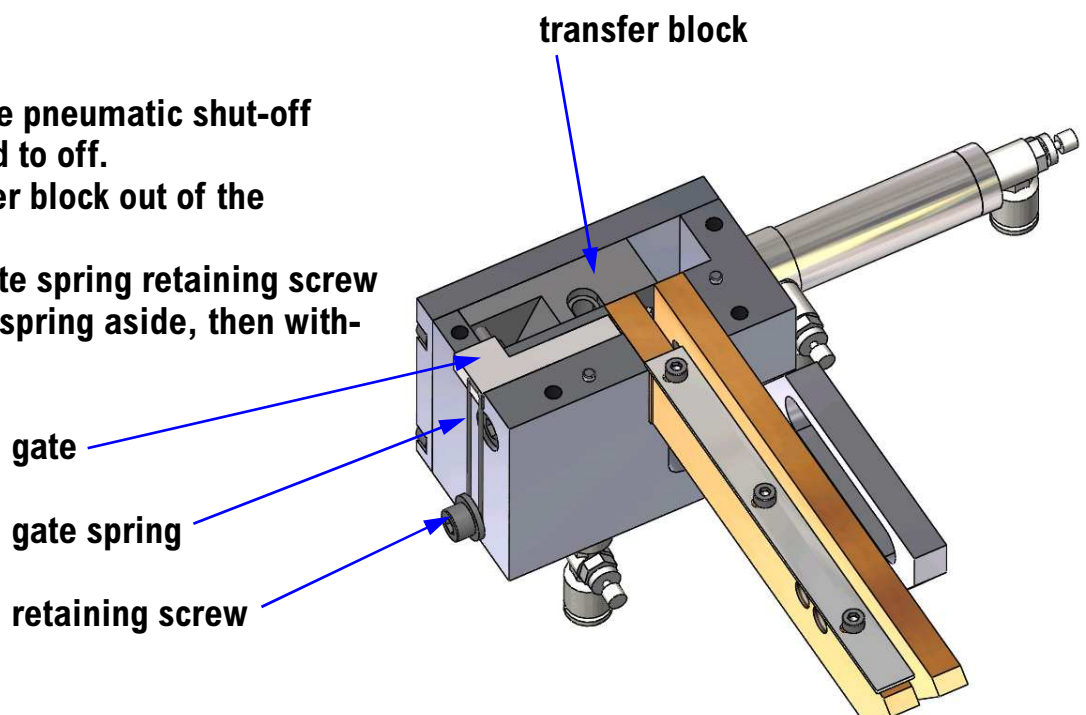

# SETTING UP

## SETTING UP THE BOWL & ESCAPEMENT

**Undo the screw holding the slide bar and remove the slide bar.**

**Undo the 3 screws holding the track cover and remove the track cover from the slide bar.**

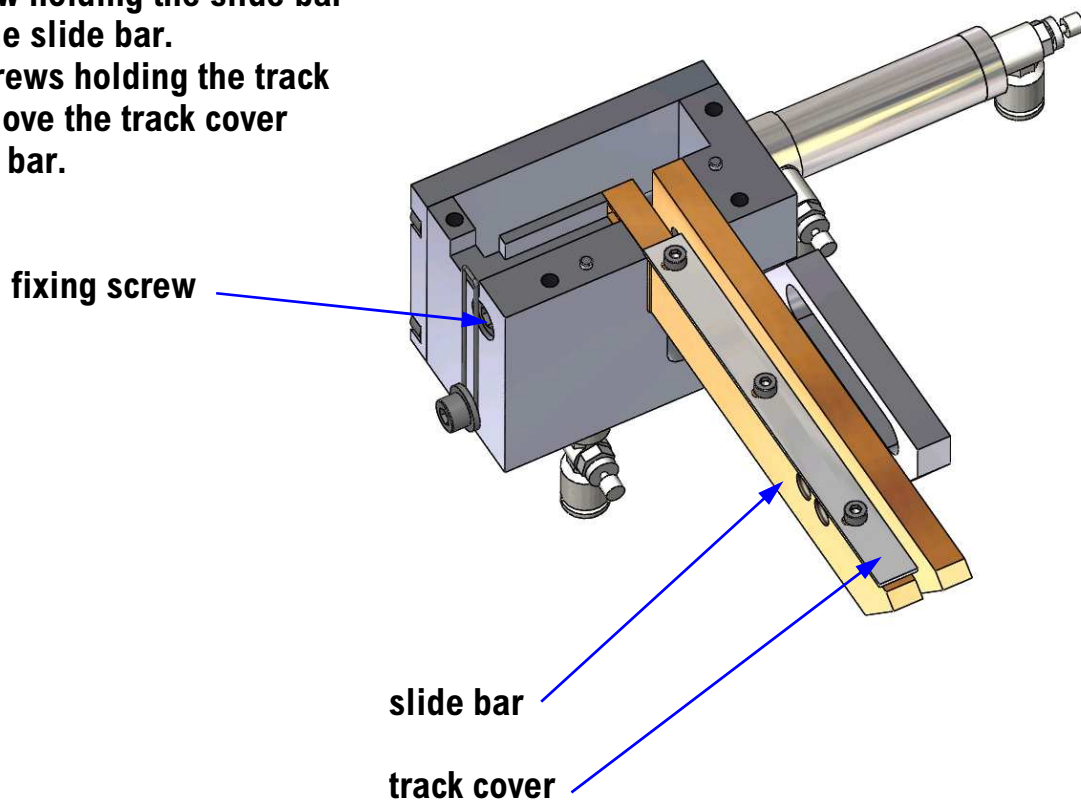

**Select the correct transfer block, gate and slide bar for the studs being used, and fit them to the escapement (see pages 19 & 20 for a list of parts).**

**Make sure that the transfer block and gate are free to move.**

**Put the gate spring back over the gate and tighten the retaining screw.**

**Refit the track cover to the slide bar.**

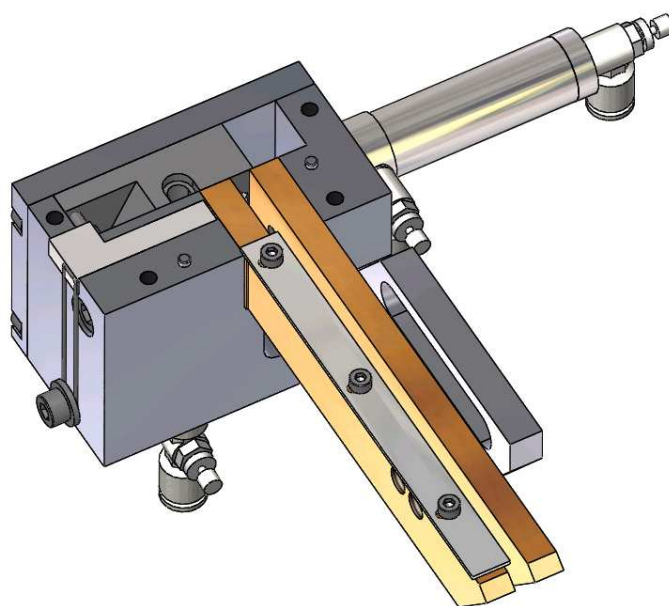

# SETTING UP

## SETTING UP THE BOWL & ESCAPEMENT

Select the correct pipe holder and top plate for the stud being used (see page 19), fit the pipe holder to the top plate and then the top plate to the escapement. Screw the feed holder gland into the pipe holder. Select the correct feed hose (see page 21) and push it in the gland and pipe holder, make sure it is pushed fully home and tighten the gland nut. This only needs to be hand tight.

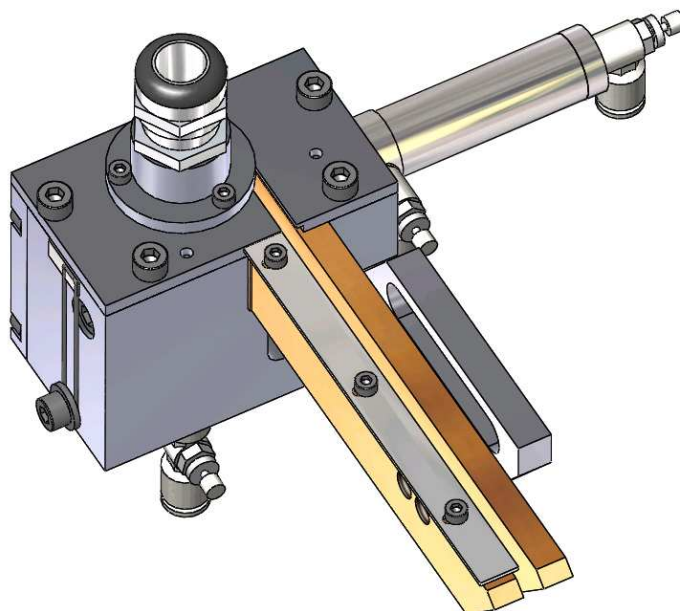

There are 2 stud sensors. The top one turns the bowl feeder on and off depending on whether it is covered or uncovered. If the bottom is uncovered it stops the system from welding.

Screw the stud sensors into the slide bar so that the inner faces of the sensorS and slide bar are flush, use the lock nut to hold them in place.

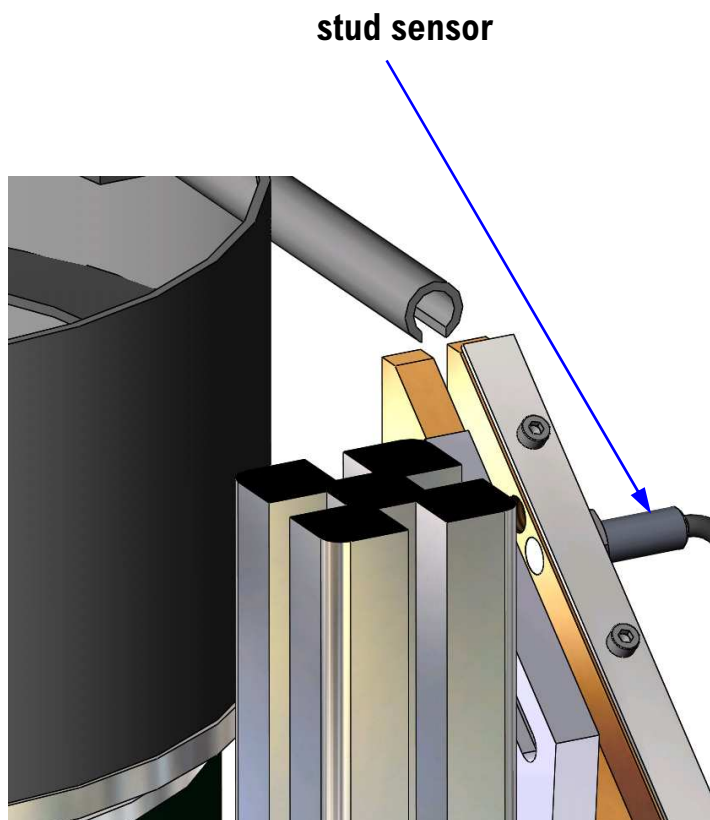

# SETTING UP

## SETTING UP THE BOWL & ESCAPEMENT

If necessary adjust the stud air flow. If the air flow is too slow the feed piston in the pistol may have returned to its rest position before the stud arrives in the weld head. Screw the adjuster in to reduce the flow and out to increase it.

air flow adjuster

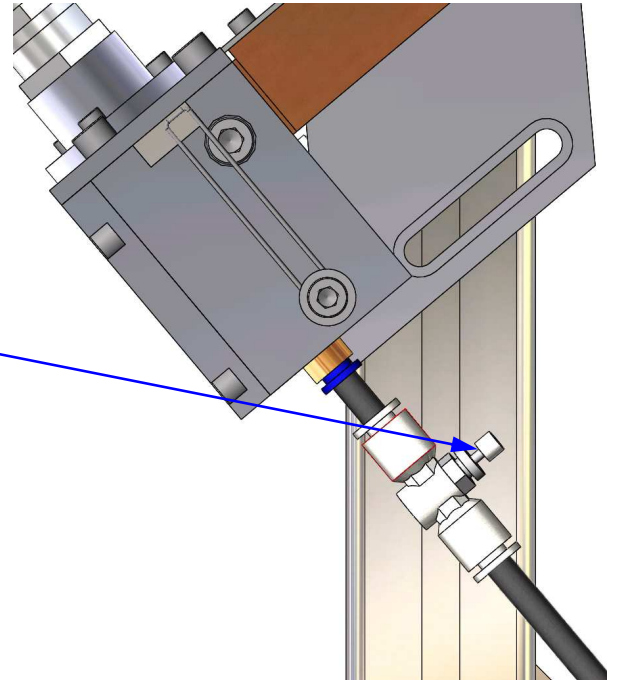

**Note:** To prevent corrosion in humid environments periodically spray the outer surfaces of the escapement with WD40 or similar protective oil.

Adjust the vibration speed to match the feed rate of the bowl and the weld rate of the weld head. This may need to be adjusted as the quantity of studs in the bowl varies, i.e. as the quantity of studs falls, the vibration speed may need to be increased.





# SETTING UP

## SETTING UP THE WELD CONTROLLER

Set up the capacitor discharge or drawn arc weld controller as shown in the manual appropriate for that piece of equipment.



# ESCAPEMENT COMPONENT EXPLOSION

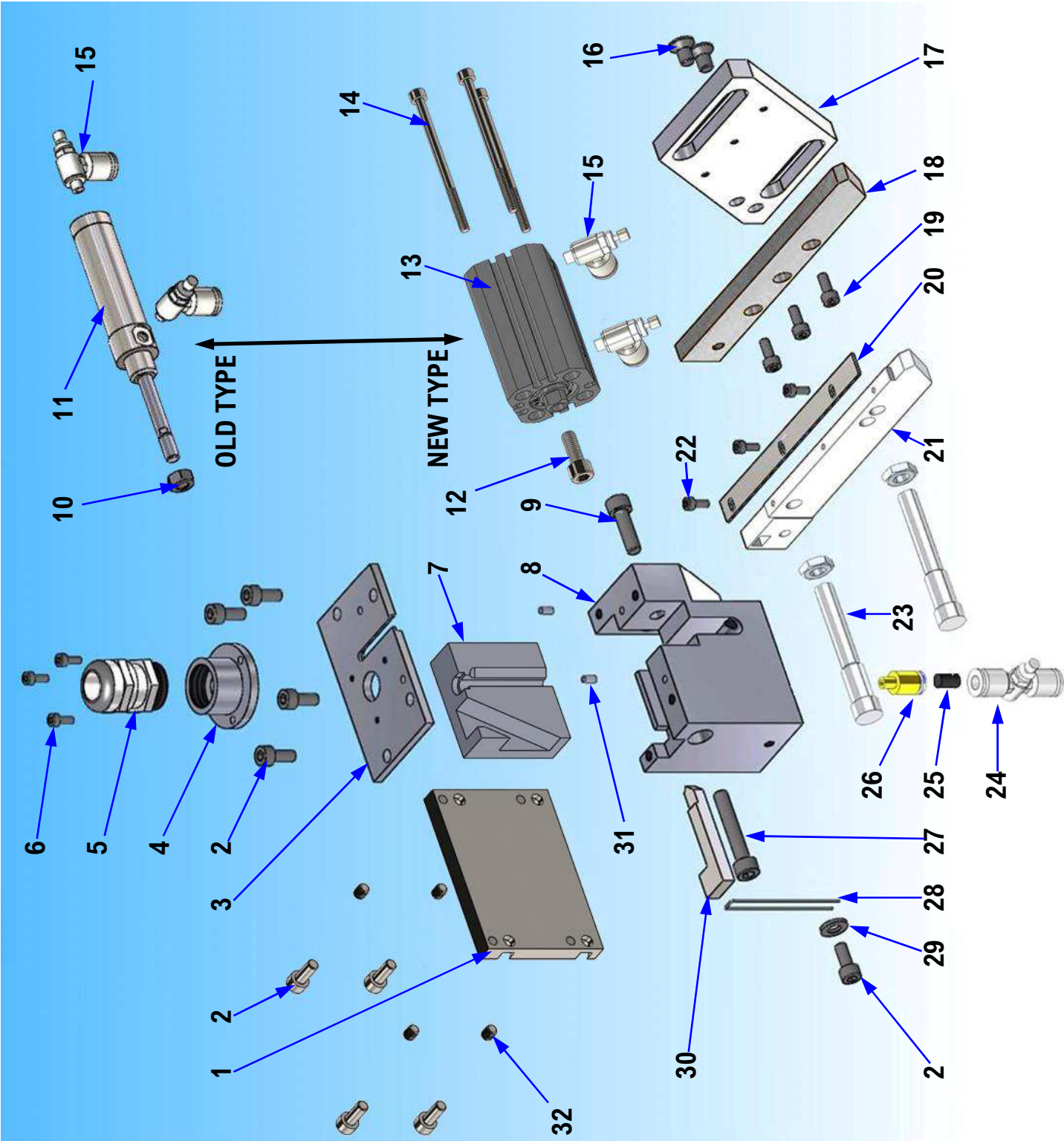



# ESCAPEMENT COMPONENT EXPLOSION

ITEM No	QTY	DESCRIPTION	PART No
1 <sup>1</sup>	1	BACKPLATE	71-103-861
2	9	SKT CAP HD SCREW M5 x 16 LONG	Z105-05-012
3	1	TOP PLATE M3 TO M10	SEE PAGE 19
4	1	PIPE HOLDER M3 TO M10	SEE PAGE 19
5 <sup>1</sup>	1	FEED HOSE GLAND	71-103-081
6	3	SKT CAP HD SCREW M3 x 8 LONG	Z105-03-008
7	1	SHUTTLE BLOCK M3 TO M10	SEE PAGE 19
8 <sup>1</sup>	1	MAIN BLOCK	71-103-860
9	1	SKT CAP HD SCREW M6 x 20 LONG	Z105-06-020
10 <sup>2</sup>	1	DRIVE NUT	71-103-927
11 <sup>2</sup>	1	DRIVE CYLINDER	71-200-209
12 <sup>2</sup>	1	DRIVE SCREW	Z100-06-016
13 <sup>2</sup>	1	DRIVE CYLINDER	71-103-982
14 <sup>2</sup>	3	CYLINDER MOUNTING SCREW	Z100-04-065
15	2	PNEUMATIC SPEED CONTROL	71-200-026
16	2	SKT CSK SCREW M6 x 10 LONG	Z120-06-016
17	1	MOUNTING PLATE	71-103-920
18 <sup>1</sup>	1	STANDARD RAIL	71-103-862
19	3	SKT CAP HD SCREW M4 x 10 LONG	Z105-04-010
20	1	TRACK COVER	71-103-911
21	1	RAIL M3 TO M10	SEE PAGE 20

<sup>1</sup> 1 For large flange stud substitute 71-103-978

5 For M10 substitute 81-108-019  
For large flange stud substitute 71-105-187

8 For large flange stud substitute 71-103-980

18 For large flange stud substitute 71-103-985

<sup>2</sup> Mechanisms manufactured before 07/2013 are fitted with items 10 & 11  
Mechanisms manufactured after 07/2013 are fitted with items 12 to 14

# ESCAPEMENT COMPONENT EXPLOSION

ITEM No	QTY	DESCRIPTION	PART No
22	3	M3 x 6 THUMBSCREW	71-103-912
23	2	STUD SENSOR	75-102-450
24	1	PNEUMATIC SPEED CONTROL	71-200-166
25	0.2m	PNEUMATIC PIPE	71-200-159
26	1	M5 x DIA 6 STRAIGHT FITTING	71-200-210
27	1	SKT CAP HD SCREW M6 x 35 LONG	Z105-06-040
28	1	GATE SPRING	71-103-919
29	1	M6 BRASS WASHER	Z605-05-000
30	1	GATE M3 TO M10	SEE PAGE 20
31	2	ALIGNMENT PIN	71-101-007
32	4	M5 x 6 HEX SKT GRUB SCREW	Z400-05-006

# PNEUMATIC DIAGRAM

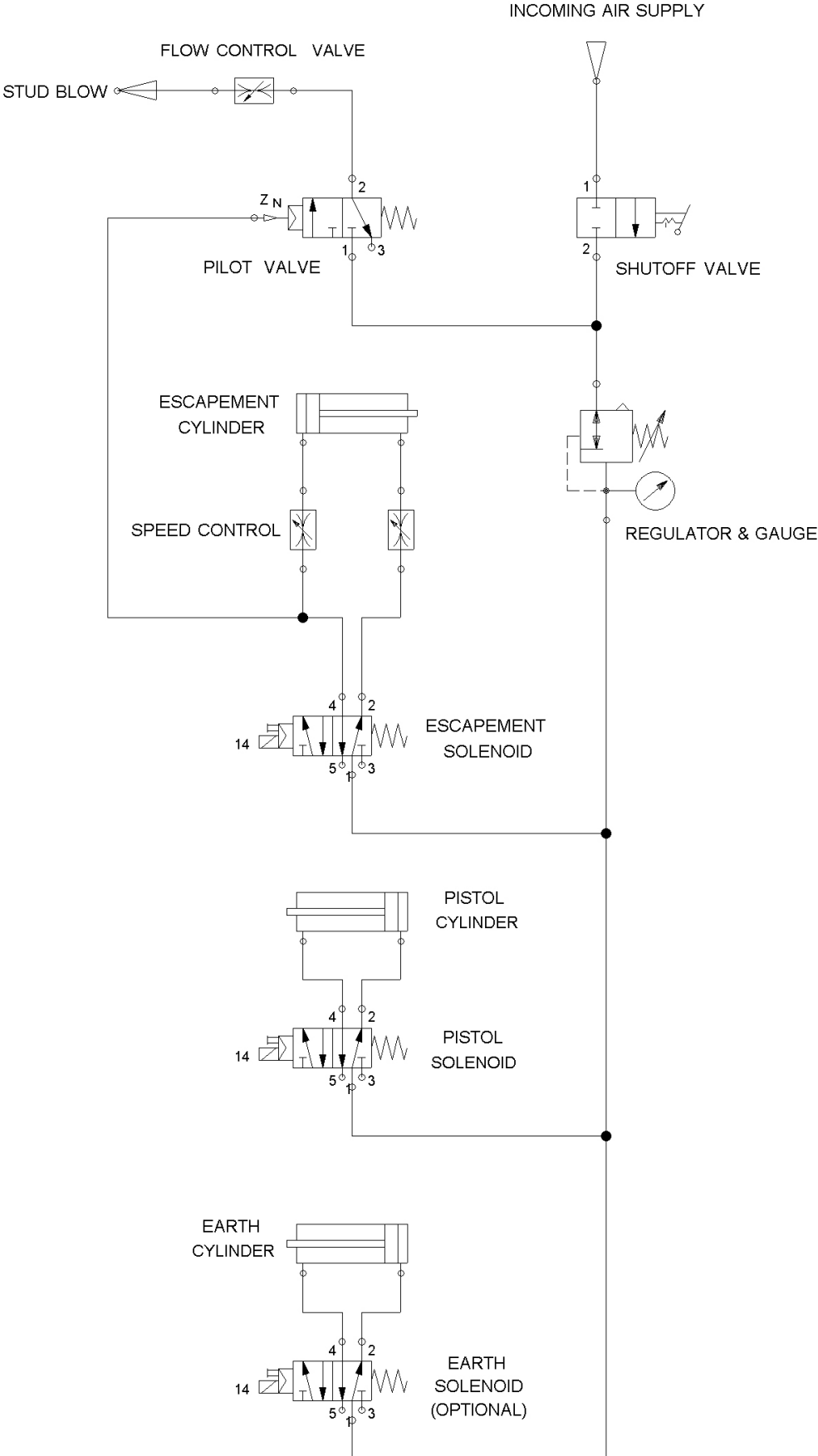

# ACCESSORIES

## ESCAPEMENT

### Transfer block

M3	71-103-863
M4	71-103-864
M5	71-103-865
M6	71-103-866
Dia 7.1	71-103-867
M8	71-103-868
M10	71-103-870
M8 L/F	71-103-970

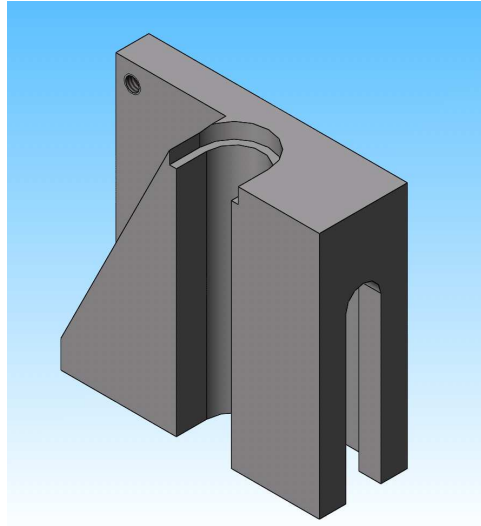

### Top plate

M3	71-103-873
M4	71-103-874
M5	71-103-875
M6	71-103-876
Dia 7.1	71-103-877
M8	71-103-878
M10	71-103-880
M8 L/F	71-103-971

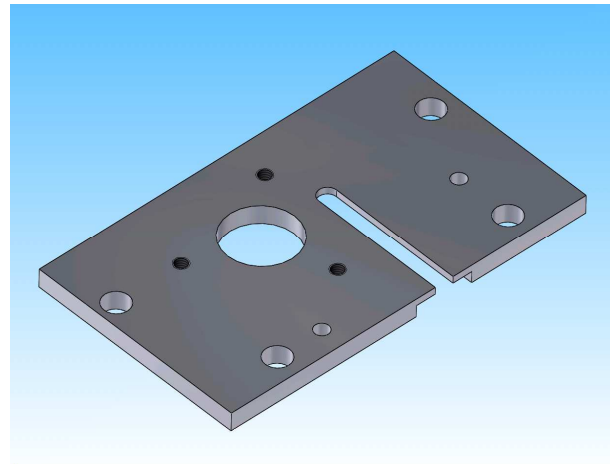

### Pipe holder

M3	71-103-893
M4	71-103-894
M5	71-103-895
M6	71-103-896
Dia 7.1	71-103-897
M8	71-103-898
M10	71-103-900
M8 L/F (16)	71-103-974
M8 L/F (14)	71-103-979

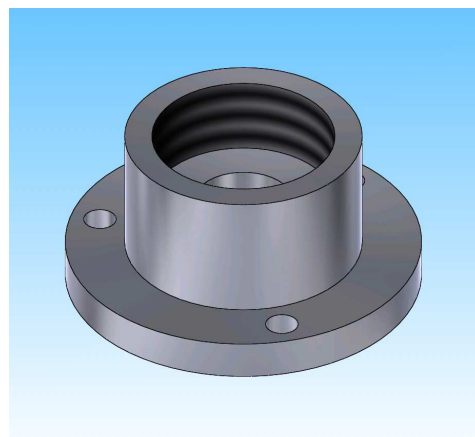

# ACCESSORIES

## ESCAPEMENT

### Gate

M3	71-103-903
M4	71-103-904
M5	71-103-905
M6	71-103-906
Dia 7.1	71-103-907
M8	71-103-908
M10	71-103-901
M8 L/F	71-103-973

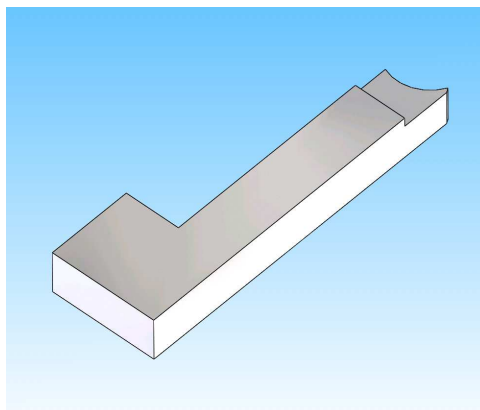

### Slide bar

M3	71-103-883
M4	71-103-884
M5	71-103-885
M6	71-103-886
Dia 7.1	71-103-887
M8	71-103-888
M10	71-103-881
M8 L/F	71-103-972

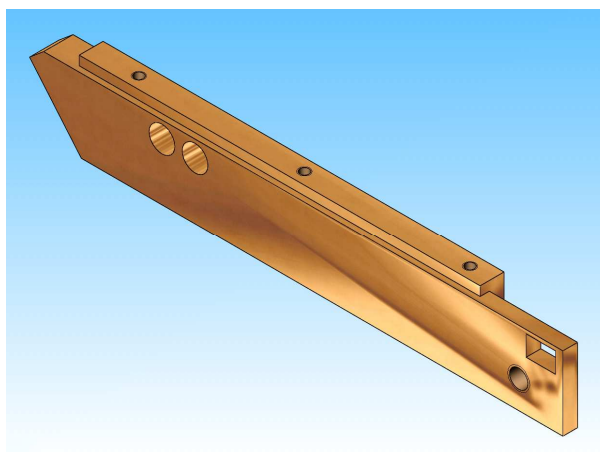

### Bowl top

M3	71-103-963
M4	71-103-964
M5	71-103-965
M6	71-103-966
Dia 7.1	71-103-967
M8	71-103-968
M8 L/F	71-103-981

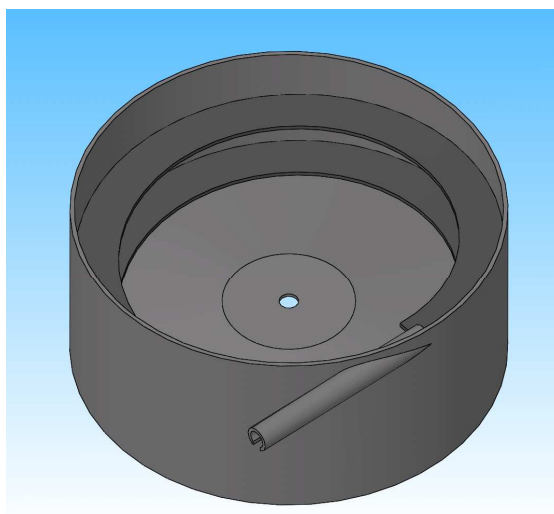

# ACCESSORIES

## Feed hose

<b>M3</b>	<b>79-103-303</b>
<b>M4</b>	<b>79-103-304</b>
<b>M5</b>	<b>79-103-305</b>
<b>M6</b>	<b>79-103-306</b>
<b>M8 &amp; Dia 7.1</b>	<b>79-103-308</b>
<b>M10</b>	<b>79-103-310</b>
<b>M8 L/F (16)</b>	<b>79-103-316</b>
<b>M8 L/F (14)</b>	<b>79-103-314</b>

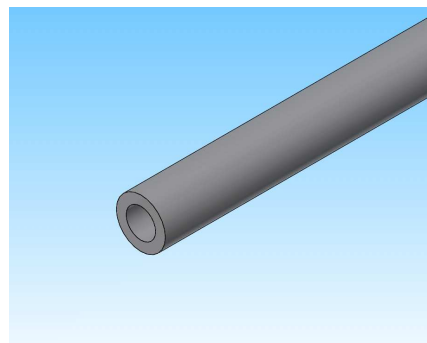

# **EC DECLARATION OF CONFORMITY**

## **TAYLOR STUDWELDING SYSTEMS LIMITED**

Hereby certifies on it's sole responsibility that the following product :

**Stud Feeder Escapement.**

Which is explicitly referred to by this Declaration meet the following Directives and Standards :

**Directive 2004/108/EC  
Electromagnetic compatibility  
Directive 93/68/EC  
CE Marking  
European Standard  
EN 50 199**

Documentation evidencing conformity with the requirements of the Directives is kept available for inspection at the above Manufacturer's headquarters.

**D. Taylor**



**Managing Director**

